

**NTSE STAGE II**  
**CODE: 13 – 15**  
**MAT**  
**Held on: May 13, 2018**

1. Which figure completes the statements?

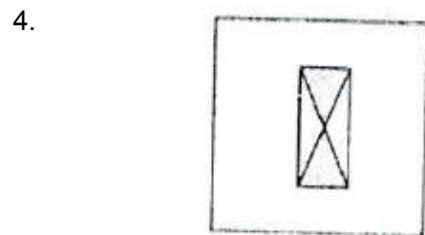
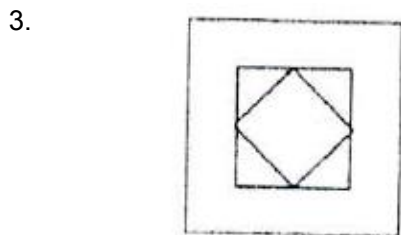
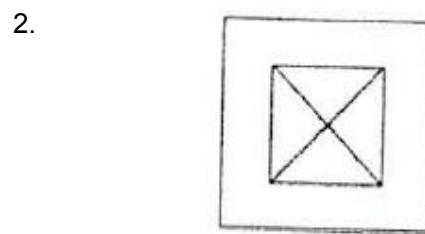
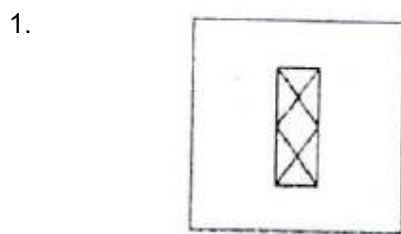
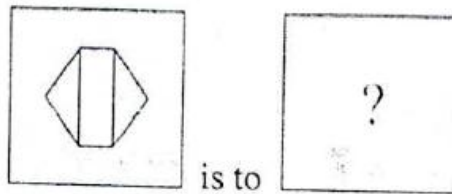
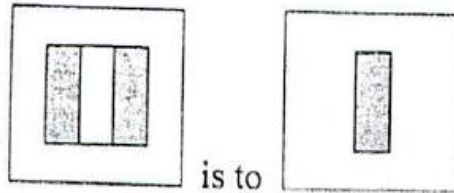

2. Fact 1: Ravneet said, "Mehtar and I both have goats."  
 Fact 2: Mehtar said, "I don't have a goat."  
 Fact 3: Ravneet always tells the truth, but Mehtar sometimes lies.  
 If the three following statements are facts, which of the following statements must also be facts?

- I. Mehtar has a goat
- II. Ravneet has a goat.
- III. Mehtar is lying

- 1. II only
- 3. I, II and III

- 2. I and II only
- 4. II and III only

3. Look at the patterns in the squares and understand their relationship to one another so as to fill in the square with missing symbols.

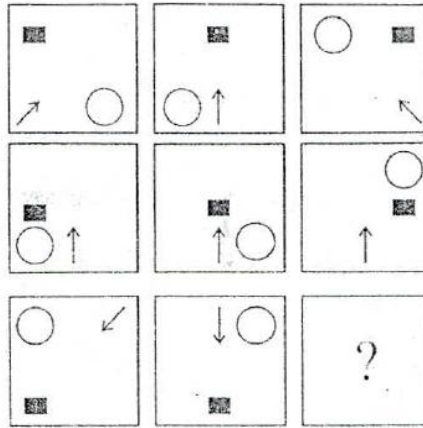

1.

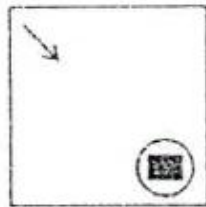

2.

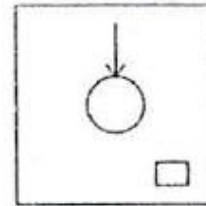

3.

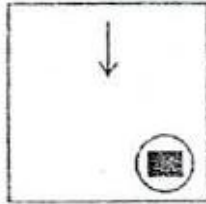

4.

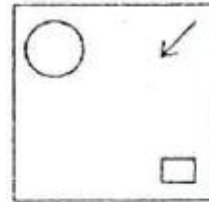

4. Danish starts walking straight towards East. After walking 75 m, he turns to the left and walks 25 m straight. Again he turns to the left, walks a distance of 40 m straight, again he turns to the left and walks a distance of 25 m.  
How far is he from the starting point?
1. 30 m
  2. 35 m
  3. 40 m
  4. 50 m

5. In the question given below, there are four statements which are to be taken as truth even if they do not seem to be so. There are conclusions numbered I, II, III and IV. Decide which of these logically follow from the given statements.  
All student who like English also like Mathematics. Some students like Hindi. All students who like Hindi do not like Mathematics. Students who like Mathematics also like English.

- I. Students who like Hindi also like English
- II. Students who like Mathematics also like Hindi.
- III. Students who like Mathematics do not like Hindi.
- IV. Students who like English do not like Hindi.

1. I and II
3. I and IV

2. I and III
4. III and IV

6. The number in the place of '?' should be

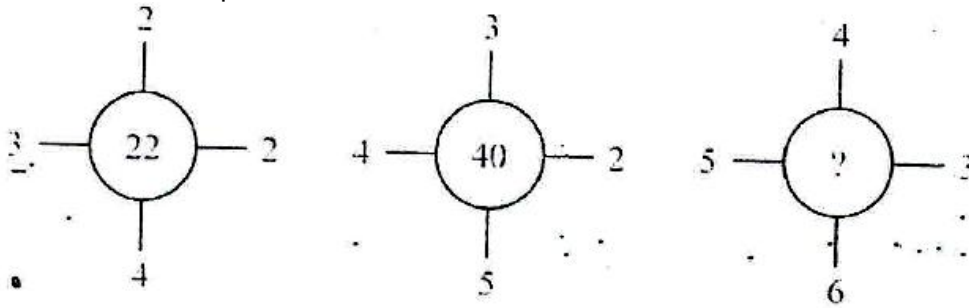

- 1. 42
- 3. 59

- 2. 58
- 4. 68

**Direction (7–9): Answer these questions by using the following diagram.**

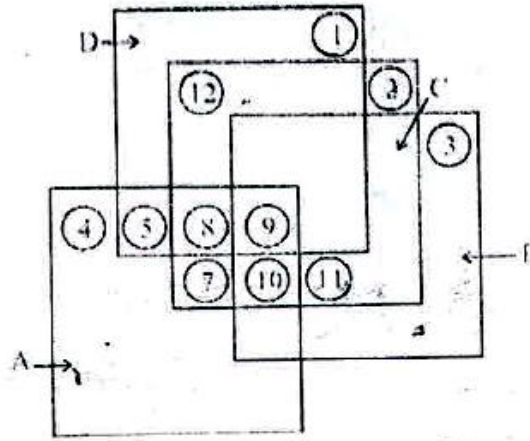

Each square stands for different class.

- A. represents Indians
- B. represents Students
- C. represents Talented individuals
- D. represents Players

7. How many Indian non-player students who are talented?

- 1. 5
- 2. 7
- 3. 10
- 4. 12

8. How many talented Indians are players?

- 1. 13
- 2. 17
- 3. 19
- 4. 22

9. How many talented Indians are there, who are students?

- 1. 13
- 2. 15
- 3. 17
- 4. 19

Direction (10–11): Study the following diagram.

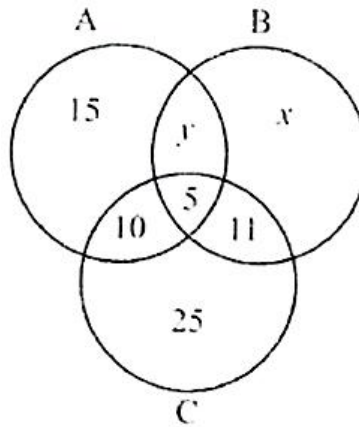

A. Representing people who read newspaper A

B. Representing people who read newspaper B

C. Representing people who read newspaper C

Based on the above information answer the question 10–11.

10. If the number of people in B is 10 more than A, what is the total number of people in only B (i.e., in B but not in A or C)?
- |       |       |
|-------|-------|
| 1. 14 | 2. 24 |
| 3. 30 | 4. 36 |
11. If sum of the number of people in only B and the number of people common in both A and B is 63 and the number of people in B is twice the number of people in A, then the values of x and y are respectively.
- |          |          |
|----------|----------|
| 1. 15, 4 | 2. 48, 5 |
| 3. 51, 7 | 4. 51, 8 |
12. In the question given below, some argument/arguments is/are logical and others are not. Identify the logical argument/arguments.
- I. Eating lots of vegetables and fruits increases immunity. I eat lots of vegetables and fruits, so my immunity is high.
  - II. Eating lots of vegetables and fruits increases immunity. I do not eat vegetables and fruits, so my immunity is low.
  - III. Eating lots of vegetables and fruits increases immunity. My immunity is low, which means I don't eat fruits and vegetables.
- |              |               |
|--------------|---------------|
| 1. only I    | 2. I and II   |
| 3. I and III | 4. II and III |

13. Consider the following figure:

🌸	🌸	🌸 🌸
🍏 🍏	🍏	🍏 🍏
🌸 🌸	🍏 🍏	🌸
🍏 🍏	🍏 🌸	
🍏 🌸	🌸 🌸	?
🍏		

Which of the following alternatives should replace the question mark?

1.

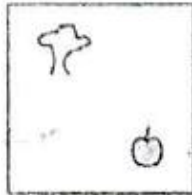

2.

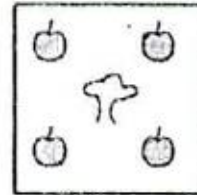

3.

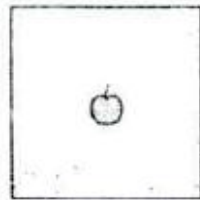

4.

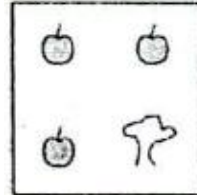

14. Find out the water image of  
AVPU7436

1. VABRΔ+30

2. VABR7439

3. VAPU7+39

4. VAPU7+30

15. A man goes on trek from the bottom to the top of a mountain. He starts at 6 am of 15<sup>th</sup> October, 2017 from the bottom and reaches the top at 6 pm of the same day. On 16<sup>th</sup> October, 2017 he starts from the top at 6 am and goes back following exactly the same route and reaches the bottom at 6 pm. Based on the above situation, the following possibilities are to be analysed.

- I. It is not possible to find a point on the route which he will cross at the same time each day.
- II. It is possible to find a point on the route which he will cross at the same time each day provided only if he travels on each day with equal uniform speed.
- III. It is always possible to find a point on the route which he will cross at the same time each day irrespective of his speed of travel.

1. Only I is true

2. Only II is true

3. Only III is true

4. Both I and II are true

16. At noon and at midnight the long and short hands of a clock are together. Between noon and midnight, how many times the long hand overtakes the short hand?

1. 9

2. 10

3. 11

4. 12

17. If MENTAL : SMXFOB then ABILITY : \_\_\_\_\_.
1. GJSXWJQ  
2. GSXWJJQ  
3. SGXWJJQ  
4. SJXQJWG
18. As JAISALMER is to JAILSARME, as HYDERABAD is to \_\_\_\_\_.
1. HYDAERDBA  
2. HYDRBEDAA  
3. HYDBDREAA  
4. HYDEADRAB
19. Which of the following alternatives will fit in the place of '?'
- AZ, GT, MN, ?, YB
1. KF  
2. RX  
3. SH  
4. TS
20. Look at this series:  
J14, L16, \_\_\_\_\_, P20, R22
- Which of the following alternatives will fit in the blank space?
1. N18  
2. S24  
3. M18  
4. T24
21. What will be the missing term in the given sequence?
- ACC, \_\_\_\_\_, CEO, DFX
1. BDD  
2. BDE  
3. BDH  
4. BED
22. Which number comes in place of '?' ?
- 64, 57, 66, 55, ?, 52
1. 68  
2. 69  
3. 70  
4. 71
23. Select the suitable figure from the given alternatives to complete the figure.

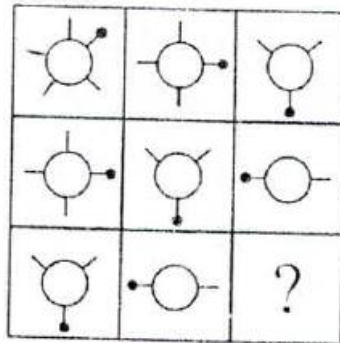

- 1.
- 2.
- 3.
- 4.

24. Arrange the given words in a meaningful sequence and find the correct sequence from the given options:
- (A) Wall (B) Clay  
(C) House (D) Room  
(E) Bricks
1. E, B, A, D, C  
2. B, E, D, A, C  
3. B, E, A, D, C  
4. A, B, C, D, E

25. Identify the figure that completes the pattern.

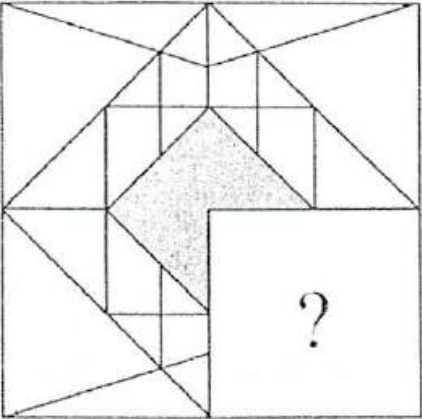

1.

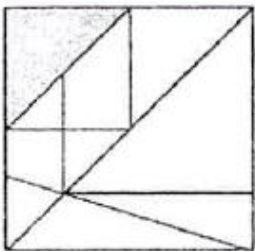

2.

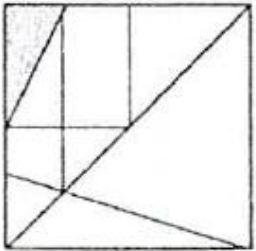

3.

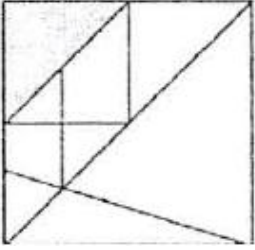

4.

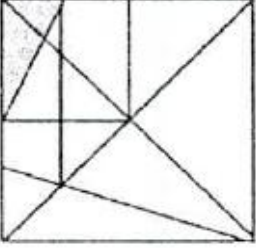

26. Replace '?' by the appropriate figure from the given options.

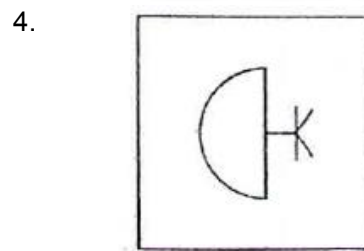
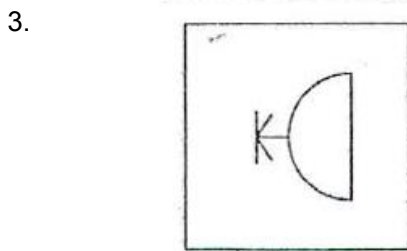
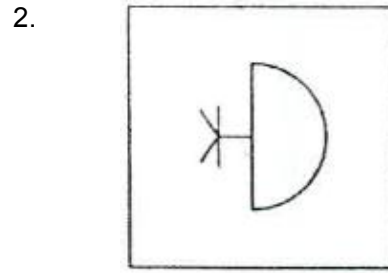
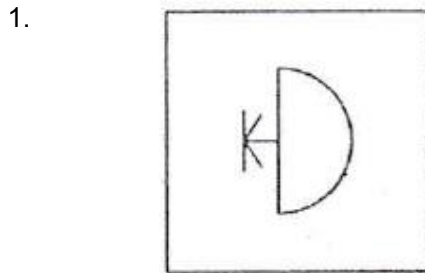
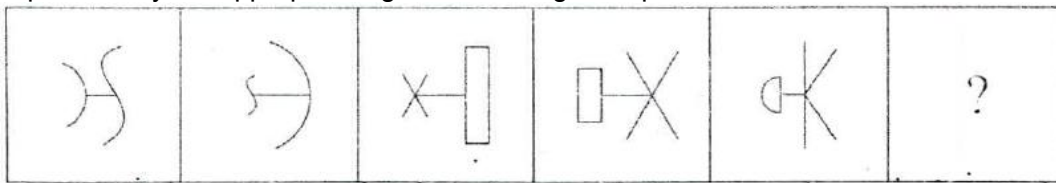

27. When a square shaped transparent sheet with the pattern shown in the figure is folded along the dotted line which pattern would appear?

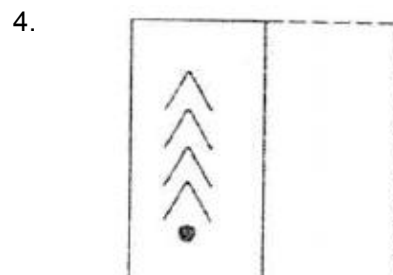
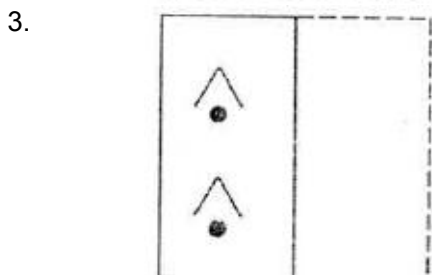
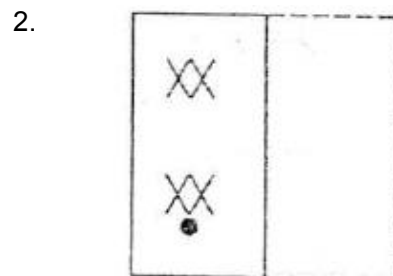
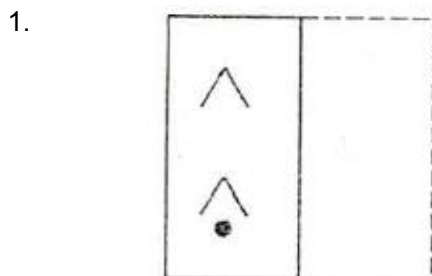
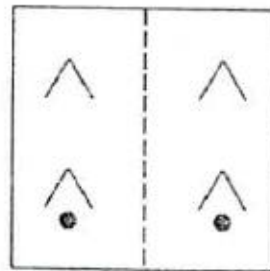



28. Fact 1: All monkeys like to jump.  
Fact 2: Some monkeys like to swim.  
Fact 3: Some monkeys look like their masters.  
If the first three statements are facts, which of the following statements must also be a fact(s)?
- All monkeys who like to swim look like their masters.
  - Monkeys who like to swim also like to jump.
  - Monkeys who like to jump do not look like their masters
- I only
  - II only
  - II and III
  - Both I and II
29. Given below the statement followed by two assumptions.  
The population below poverty line has increased in urban area during the last year.  
Assumptions:
- The population below poverty line has decreased in rural area.
  - The population below poverty line has not increased during the current year.
- Which of the assumptions is/are implicit in the statement?
- Only I is implicit
  - Only II is implicit
  - Either I or II is implicit
  - Neither I nor II is implicit
30. Identify the conclusion(s) which logically follow(s) from the given statements:  
A. Some men are educated.  
B. Educated men prefer small families
- Conclusions:
- All small families are educated.
  - Some men prefer small families.
- Only conclusion I follows
  - Only conclusion II follows
  - Both I and II follow
  - Neither I nor II follows
31. A watch is showing right time at 9 pm. This watch gains 10 minutes in every 24 hours. What will be the time shown next day by the watch when the correct time is 2 am?
- 02:00:24 am
  - 02:00:48 am
  - 02:02:05 am
  - 02:02:30 am
32. In a school, students are offered subjects in such a manner that they have to choose at least one subject from History and Geography, Accordingly:  
All students who study History also study Geography logically implies:
- There are no students who study Geography and do not study History.
  - There are no students who study History and do not study Geography.
  - There are no students who do not study History and do not study Geography.
  - All students who do not study Geography are students who study History.
- I and II
  - I and III
  - II and III
  - II and IV

33. In a city, all the roads are either parallel to the East-West or North-South direction. Every  $\frac{1}{8}$ th of a kilometer from each road there is crossing and the square area covered between four crossings is called a block. Starting from a crossing, if I travel four blocks north, take left and then travel three blocks west, I reach another crossing. What is the distance between these two crossings?

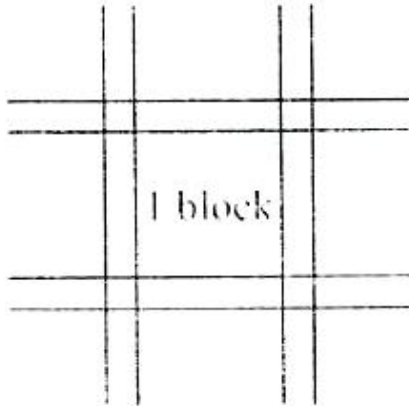

1. 5 km  
2. 7 km  
3.  $\frac{7}{8}$  km  
4.  $\frac{5}{8}$  km
34. How many minimum right turns will you make to reach school from home?

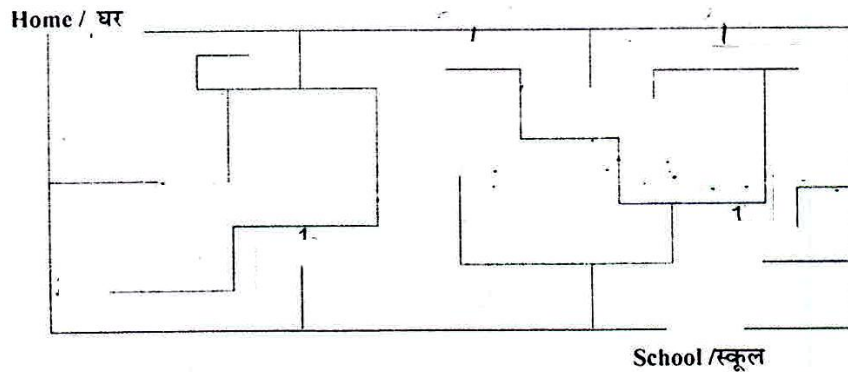

1. 7  
2. 8  
3. 9  
4. 10

35. The figure shows the Gender, Marital Status and Profession (GMP) of a number of people. Each shape show a different GMP.

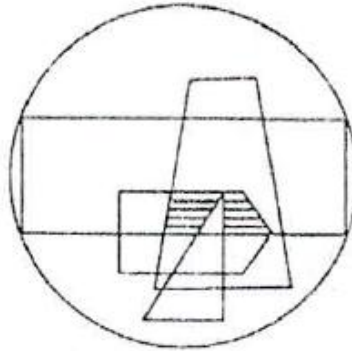

Circle indicates total population, trapezium is males, pentagons is married, rectangle is teachers, and triangle is doctors.

What do the shaded regions represent in the diagram?

1. married males who are teachers
2. unmarried males who are doctors
3. unmarried females who are doctors
4. married males who are neither doctors nor teachers

Directions (Questions 36 - 38):

Each of integers 1 to 26 is represented in the Venn diagram in the appropriate regions P to W where region

K - represents integers from 1 to 26

I - represents even integers from 1 to 26

II - represents perfect square integers from 1 to 26

III - represents prime numbers from 1 to 26

W - represents numbers from 1 to 26 other than those in I, II and III

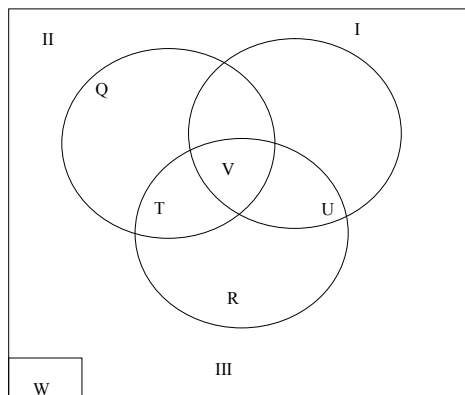

36. Which region contains exactly two integers?
- |                 |                 |
|-----------------|-----------------|
| 1. P and W only | 2. R and U only |
| 3. S and W only | 4. U and W only |
37. The total number of integers in S and R is equal to the number of integers in
- |           |           |
|-----------|-----------|
| 1. P only | 2. T only |
| 3. V only | 4. W only |
38. Which region contains exactly eight integers?
- |      |      |
|------|------|
| 1. P | 2. Q |
| 3. R | 4. S |

39. In a school, commerce and arts subjects were offered. Some students opted only for commerce and some only arts. There were science students also who did not choose any of these subjects. The rest of them accepted both commerce and arts. Which one of the following Venn diagram correctly reflects this situation.

1.

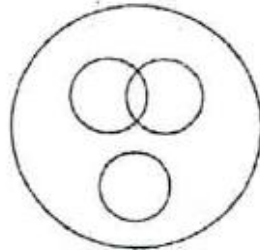

2.

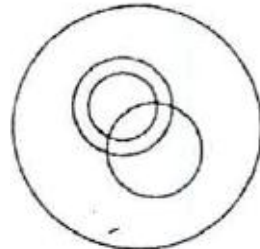

3.

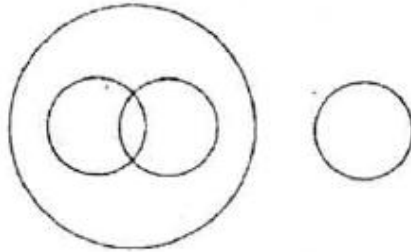

4.

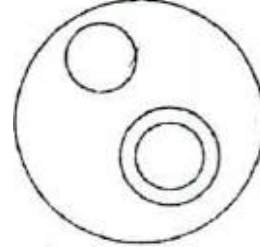

40. A person walked 100 m straight from the point 'A' in the North – East direction, walked 200 m in South – West direction from there, 100 m in North – East direction again, walked 100 m eastward, 200 m southward and 100 m westward to reach at the point 'B'. Choose the right answer from the following to find out his/her distance and direction from 'A'.

1. 100 m North

2. 100 m South

3. 200 m North

4. 200 m South

Directions (Questions 41 - 44)

Items 41 – 44 each contains a question of two statements I and II, giving certain data. Select the correct answer from (1) to (4) depending on the sufficiency of data given in the statements to answer each question.

- (1) If I alone is sufficient and II alone is not sufficient to answer the question.  
 (2) If II alone is sufficient and I alone is not sufficient to answer the question.  
 (3) If both I and II together are sufficient but neither statement alone is sufficient to answer the question.  
 (4) If both I and II together are not sufficient to answer the question and additional data specific to the question are needed.

41. A, B and C have money with them in the ratio 5 : 3 : 1. How much money does B have?

I. A has Rs 60 more than C

II. The money with B is 40% less than the money with A

1. (1)

2. (2)

3. (3)

4. (4)

42. What is the cost of each pen?

I. The cost of 6 pens and 5 pencils is Rs 30.

II. If the cost of each pen and each pencil is reduced by 40%, then the cost of 12 pens and 10 pencils will be Rs 36

1. (1)

2. (2)

3. (3)

4. (4)

43. What is the ratio of savings of A and B?  
 I. The ratio of income of A and B is 5 : 6  
 II. The ratio of expenditure of A and B is 3 : 4  
 1. (1) 2. (2)  
 3. (3) 4. (4)
44. What is the ratio of the selling prices of two articles A and B?  
 I. The cost price of article A is equal to the selling price of B  
 II. The profit made by selling A is equal to  $\frac{1}{5}$  of its selling price  
 1. (1) 2. (2)  
 3. (3) 4. (4)
45. If in a code language STAR = 50 and CIRUS = 65 then PLANET will be  
 1. 68 2. 78  
 3. 84 4. 94
46. Pankaja puts her alarm clock on the table in such a way that at 6 pm the hour hand points to North. In which direction will the minute hand point at 9 : 15 pm?  
 1. South - East 2. South  
 3. North 4. West
47. One evening before sunset two friends Rajni and Sanjiv were talking face to face. If Sanjiv's shadow was exactly to his right side, to which direction Rajni was facing?  
 1. North 2. North - East  
 3. South 4. South-East
48. The square boxes in the figure below are to be painted with different colours such that no two adjacent boxes (even diagonally) have same colour. How many minimum colours do you need in each case?

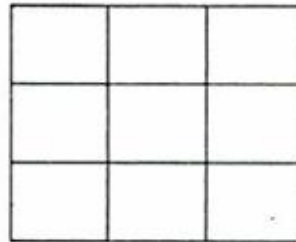
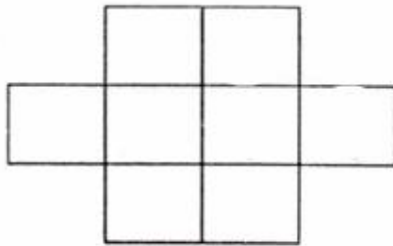

1. (3, 4) 2. (4, 4)  
 3. (4, 5) 4. (3, 5)
49. What is the number in place of "?"  
 2Y23, 3V19, 5V17, 7T13, 11V11, ?  
 1. 13T7 2. 13V9  
 3. 13W9 4. 13U7
50. Identify which number does not fit in the sequence?  
 156, 182, 210, 240, 282, 306  
 1. 182 2. 210  
 3. 282 4. 306
51. What is the number in place of "?"  
 6, 15, 35, ?, 143, 221  
 1. 45 2. 65  
 3. 77 4. 93

52. A pattern is being followed to derive numbers using two out of the six numbers appearing on the faces of a dice having numbers from 4 to 9, both inclusive. Two such pairs yield 106 and 52. What will the third pair yield?

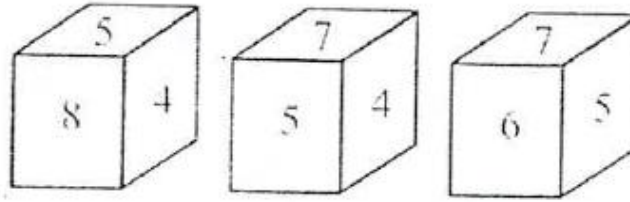

1. 100  
2. 113  
3. 130  
4. 145

53. Which group of letter given in the alternatives will complete the sequence?

a\_tta\_ant\_an\_nt\_an

1. a t n t t  
2. n n t a t  
3. n a n t t  
4. t n t a t

Directions(Questions 54 -57)

A group of students is sitting in such a way that each occupied a corner of a hexagonal table. Ninong is sitting opposite to Yaangba, Ribiya is sitting next to Silva, Nazeli is sitting opposite to Silva, but not next to Ninong, one person is sitting between Talyang and Yaangba.

54. Who is sitting opposite to Ribiya?  
1. Yaangba  
2. Silva  
3. Talyang  
4. Nazeli
55. Who is sitting between Ribiya and Ninong?  
1. Yaangba  
2. Nazeli  
3. Talyang  
4. Silva
56. Who is sitting between Talyang and Yaangba?  
1. Nazeli  
2. Ribiya  
3. Ninong  
4. Silva
57. If Talyang sits to the right of Ninong, who is on the left of Ninong?  
1. Ribiya  
2. Nazeli  
3. Yaangba  
4. Silva

58. A cylinder is painted in 6 colours – Violet, Red, Blue, Green, Yellow and Orange. The three positions of the cylinder are as follows. Looking at these figures, identify the correct colour of the place of '?'

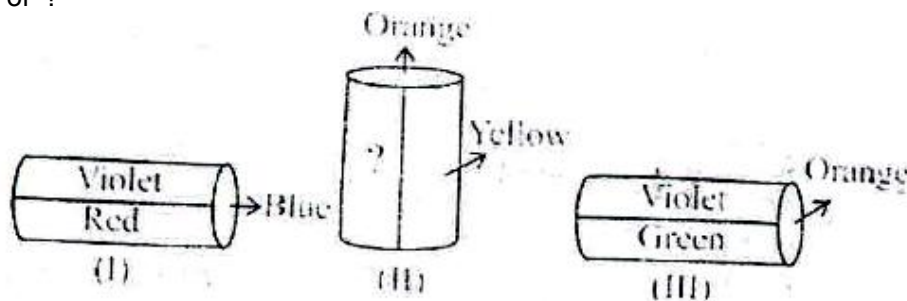

1. Red  
2. Blue  
3. Green  
4. Violet

59. Find the missing number at the place of 'M' ?

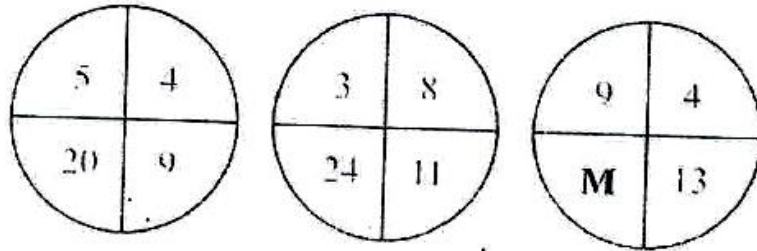

- 1. 36
- 3. 81

- 2. 52
- 4. 117

60. Which letter replace the question mark (?)

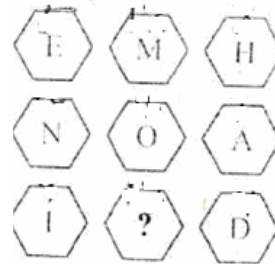

- 1. A
- 3. H

- 2. E
- 4. M

61. Which letter replace the question mark (?)

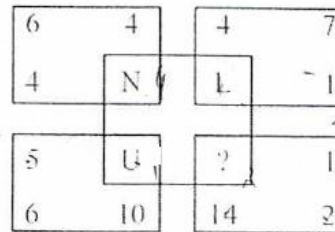

- 1. M
- 3. P

- 2. O
- 4. Q

62. What is the number that should come in place of 'M'?

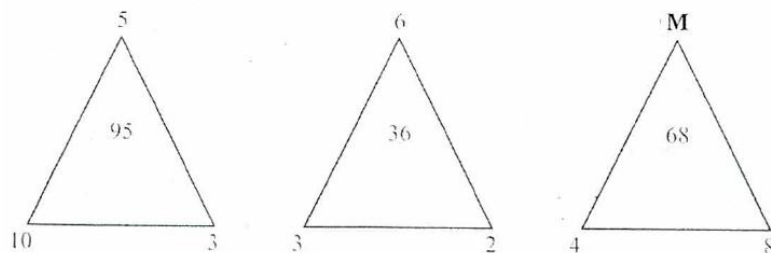

- 1. 2
- 3. 4

- 2. 3
- 4. 6

63. In the given figure which number should replace 'M'?

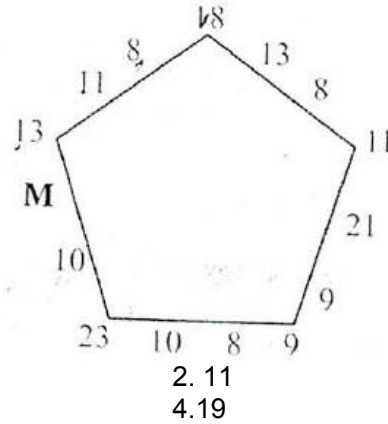

1. 4  
2. 11  
3. 13  
4. 19
64. Manushi remembers that birthday of Chaitra is after July 10 but before 17, but Vishakha remember that it is between 15 and 27 July, both inclusive. If July 10 was a Thursday and if both of them remember correctly then on which day was Chaitra's birthday?  
1. Sunday  
2. Monday  
3. Tuesday  
4. Wednesday

65. A family consist of six members P, Q, R, X, Y, Z.  
Q is the son of R but R is not mother of Q.  
P and R are a married couple.  
Y is the brother of R. X is the daughter of P. Z is the brother of Q.  
Which symbol represents all the children of P?  
1. QXYZ  
2. QXZ  
3. XZR  
4. QZ

66. I noticed that my watch goes  $\frac{1}{2}$  minute fast at dusk, but at dawn it loses  $\frac{1}{3}$  minute.  
On 1<sup>st</sup> March morning my watch showed right time, then on which of the following dates the watch was minutes fast?  
1. 28<sup>th</sup> March  
2. 29<sup>th</sup> March  
3. 30<sup>th</sup> March  
4. 31<sup>st</sup> March

67. What is the length 'x' of the line segment CD in the triangle drawn below?

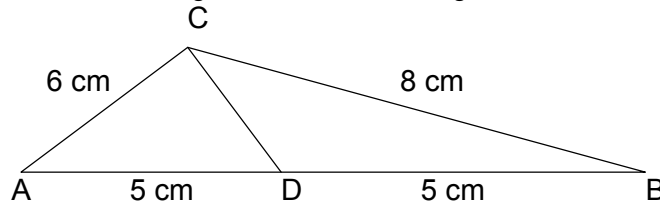

1. 4  
2. 5  
3. 6  
4. 8
68. If  $m + n = o + p$   
 $m + q = p + n$   
 $2p < m + q$  and  $2m > o + n$ , then  
1.  $o > m > n > p > q$   
2.  $m > o > p > n > q$   
3.  $n > o > p > m > q$   
4.  $o > p > n > q > m$

69. If water image of OXIDE is OXIDE, then water image of METAL will be:

1. 2. 3. 4.



70. How many dots lie opposite the face having three dots, when the given figure is folded to form a cube?

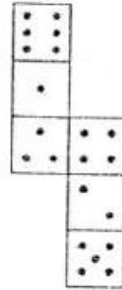

1. 2  
3. 5

2. 4  
4. 6

71. If  $\div$  is  $+$ ,  $\times$  is  $-$ ,  $-$  is  $\div$  and  $+$  is  $\times$ , then what is the value of  $20 \div 4 \times 12 - 6 + 11$

1. 2  
3. 56

2. 5  
4. 65

72. Six dice are stacked as shown in the figure. On each dice, the sum of number appearing on a face and on the face opposite to it is 7.

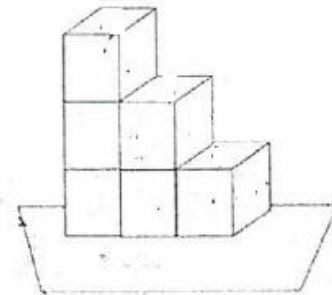

What is the maximum possible sum of the numbers on the visible faces

1. 88  
3. 96

2. 89  
4. 147

73. Observe the sequence given below and select the appropriate alternative which will remain the series .

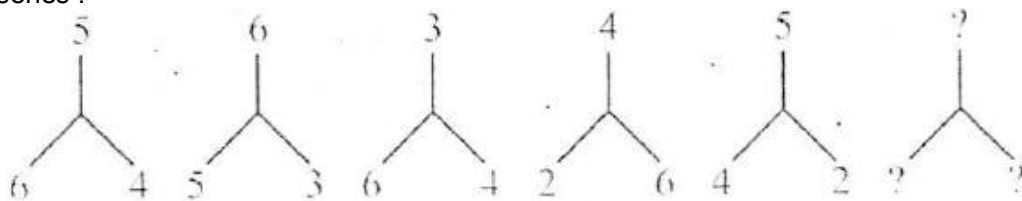

1.

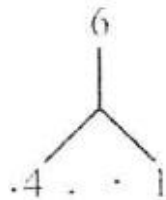

2.



3.

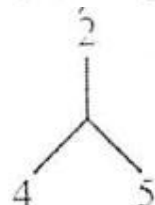

4.



74. Two positions of a dice are shown. When number 3 is on the top, what number will be at the bottom?

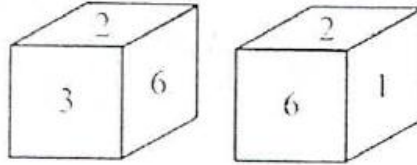

1. 1 but not 4  
2. 4 but not 1  
3. 5 or 4  
4. 5 but no 4
75. Which interchange of signs and number would make the equation correct?  
 $(96 \div 128) + 64 = 2$
1. + and  $\div$ , 64 and 96  
2. + and  $\div$ , 64 and 128  
3. + and  $\div$ , 96 and 128  
4.  $\div$  and +, 94 and 128
76. Let '%' stands for 'is equal to', '?' for 'greater than', '#' for 'lesser than'. If  $6x\%5y$  and  $2y?3z$ , then
1.  $2x?3z$   
2.  $4x?5z$   
3.  $2x\#z$   
4.  $4x\%3z$
77. If Q means 'addition sign', J means 'multiplication sign', T means 'subtraction sign' and K means 'division sign', then  
 $30 K 2 Q 3 J 6 T 5 = ?$   
 Find the number in place of '?'
1. 18  
2. 28  
3. 31  
4. 103
78. Which figure should come next among the options given below.

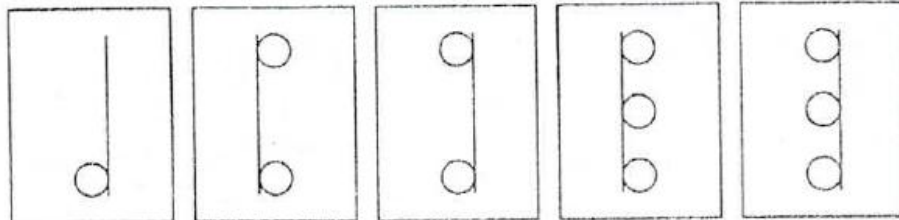

- 1.
- 2.
- 3.
- 4.

79. Observe the trends in figures given below and find the missing character.

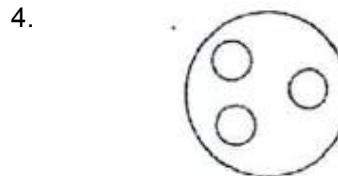
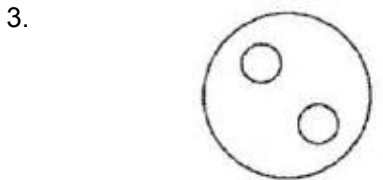
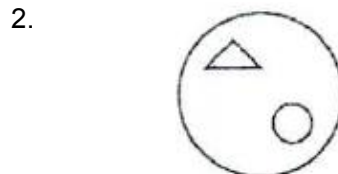
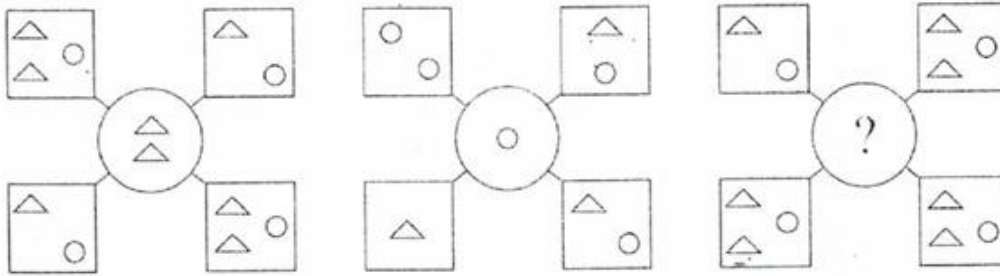

80.

Equivalent Signs	+	-	×	÷	=	(	)
	→	←	↑	↓	↕	[	]

What will come in place of '?'

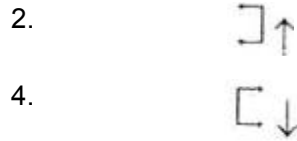
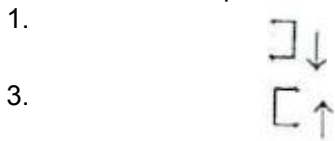

81. Complete the missing pattern?

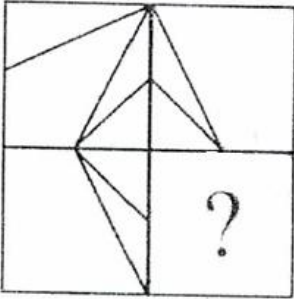

1.

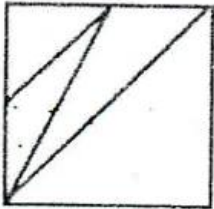

2.

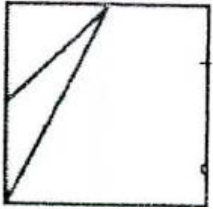

3.

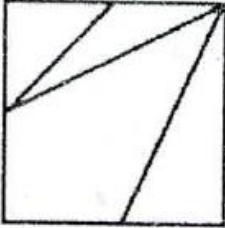

4.

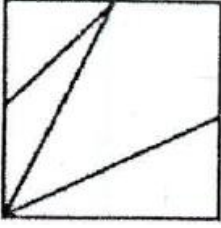

82. Find the number of rectangles in the following figure.

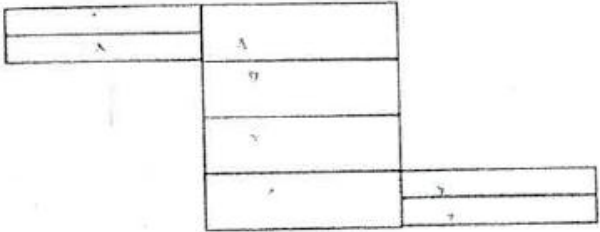

- 1. 18
- 3. 16

- 2. 17
- 4. 15

83. In the given matrix, first row and the first column consist of symbols and numbers respectively, the combination of those would be the code for specific alphabets given in other cells. For example, the code for 'G' could be 1\$ or 2@. In the same manner, what from the given alternatives will be the correct code for 'PEACE'?

	@	#	*	\$
0	A	P	Q	P
1	T	P	S	G
2	G	R	N	E
3	F	M	O	T
4	C	E	A	C
5	J	R	P	V
6	A	B	L	J
7	E	Q	C	Z

1. 0\$4#0@7\*2#  
3. 5\*7@4\*1\$2@

2. 1#3@6@4\$4#  
4. 0\$2\$0@6\*2#

84. A square sheet is folded into half, the line of folding being parallel to a side of the square. It is again folded into half, the line of folding being parallel to the shorter side. In this condition the front of the paper always appears as it is given in the figure below (the dotted lines represent the folded portions).

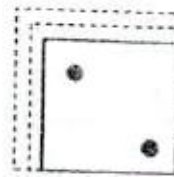

From the alternatives choose the correct figure which represents the paper in to original unfolded form.

1.

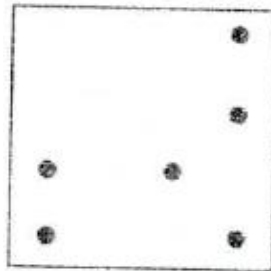

2.

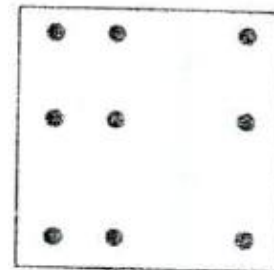

3.

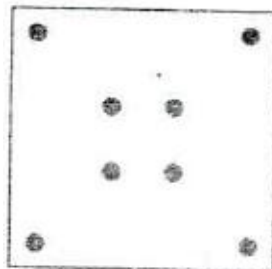

4.

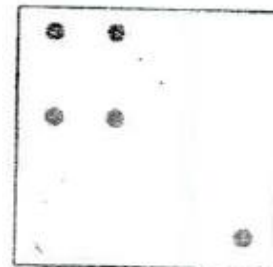

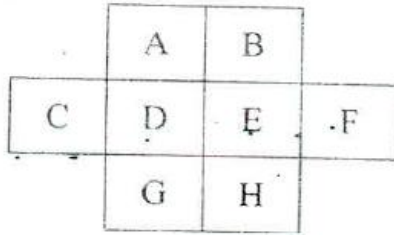

A, B, C, D, E, F, G, H are each to be assigned a different number from 1 to 8. What should be values of B, D, E, F, and G so that no consecutive numbers are in adjacent (even diagonally) squares.

Given : A = 5, C = 2, H = 4

- |                    |                    |
|--------------------|--------------------|
| 1. (6, 8, 1, 7, 3) | 2. (3, 8, 7, 1, 6) |
| 3. (8, 6, 3, 7, 1) | 4. (3, 8, 1, 7, 6) |

86. In a farmhouse there are 50 hens, 40 goat and 8 camels which are maintained by a few supervisors. If the total number of feet be 224 more than the number of heads in the farmhouse then the total number of supervisors is

- |       |       |
|-------|-------|
| 1. 5  | 2. 8  |
| 3. 10 | 4. 15 |

87. If in a coded language.

'Busy bees' are coded as 'Cpu cff'  
 'busy crows are coded as 'cpu hup',  
 'Bright Crows' are coded as 'Csj Hup'

Then, ' Busy crows are clever' will be coded as \_\_\_\_\_.

- |                    |                    |
|--------------------|--------------------|
| 1. Cpu Hup Bsf Dmf | 2. Cpu hup bsf dmf |
| 3. cpu Hup Baf Dmf | 4. cpu hup bsf Dmf |

88. What is the code used for 'Blue' derived from the given coded statements as per a code language?

I. 'Flower Blue Red White' is coded as 'Sa Ra Ga Ma'  
 II. 'Take Red Pink Flower' is coded as 'Sa Ha Ma Pa'  
 III 'Take Blue Red Buds' is coded as 'Pa Da Ma Ga'  
 IV 'Bring Red Take White' is coded as 'Ma Na Pa Ra'

- |       |       |
|-------|-------|
| 1. Sa | 2. Ga |
| 3. Pa | 4. Ra |

89. What will be the number of digits used in numbering the pages of a book having 199 pages

- |        |        |
|--------|--------|
| 1. 398 | 2. 489 |
| 3. 495 | 4. 532 |

90. In certain code 678 means 'study very hard', 347 means 'hard work pays' and 246 means 'study and work'. Which of the following is the code for 'very'?

- |      |      |
|------|------|
| 1. 4 | 2. 6 |
| 3. 7 | 4. 8 |

91. In a certain code 'TOME' is written as '@\$\*?' and 'ARE' is written as '!&?' How can 'REMOTE' be written in that code?

- |               |                 |
|---------------|-----------------|
| 1. &?!@?      | 2. &?* \$ @ ?   |
| 3. @?* \$ @ ? | 4. * @ \$ * ? ! |

92. If in a certain code 23 x 26 = 42 and 11 x 15 = 19 then, 32 x 16 = ?

- |       |       |
|-------|-------|
| 1. 40 | 2. 41 |
| 3. 44 | 4. 48 |

93. In a family of 6 (A, B, C, D, E and F) members, there is one married couple with equal number of male and female members. Read the following relations and find out the one from the alternatives, which is not true for the given family.  
Relation:-  
A and E are sons of F.  
D is the mother of a boy and a girl.  
B is the son of A.  
1. A, E, B are males  
2. C is the granddaughter of F  
3. C is the daughter of E  
4. D is the wife of A
94. If P + Q means P is husband of Q, P/Q means P is sister of Q, P\*Q means P is the son of Q. How is D related to A in D \*B + C/A?  
1. Son  
2. Nephew  
3. Sister  
4. Couple
95. Afsana was walking in a desert. Anwar was passing by riding on a camel. Afsana requested for a lift. Anwar said he will give lift only to those who are related to him. At this, Afsana told him that Anwar's mother – in – law is the mother of her mother – in – law. How is Anwar related to Afsana ?  
1. Father  
2. Maternal uncle  
3. Brother – in – law  
4. Father – in – law
96. A person travels from Mumbai to Ahmedabad by car in 5 hours. The speed of the car during first hour of journey was 60 km/hr. For the next two hours speed was 80 km/hr. Next hour it was 100 km/hr. Finally, during the last hour of his journey he drove at 40 km/hr. What is the average speed during his journey?  
1. 56 km/hr  
2. 67.4 km/hr  
3. 70 km/hr  
4. 72 km/hr

Directions for (Questions 97 – 98)

Study the pie chart and information given below and answer the following questions.

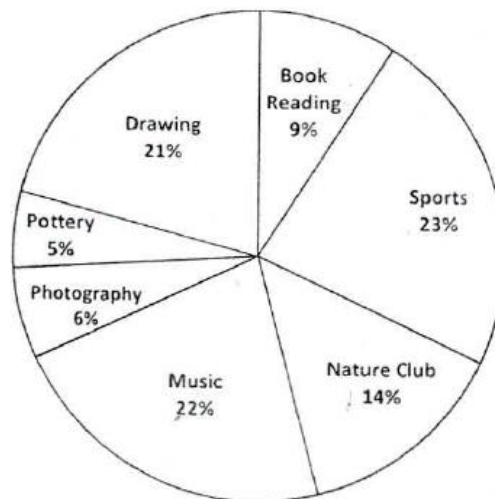

There are 1150 students of a school opted sports as a hobby.

97. How many students have books reading as a hobby?  
1. 390  
2. 420  
3. 440  
4. 450

98. What is the total number of students in the school?
1. 4990
  2. 5000
  3. 5050
  4. 5100

99. The following table shows the distribution of Boys and Girls students of seven different schools.

School	Boys (Total 27,300)	Girls (Total 24,700)
A.	17%	8%
B.	12%	15%
C.	12%	12%
D.	13%	13%
E.	19%	14%
F.	14%	21%
G.	15%	17%

What is the ratio between the number of Girls and Boys students respectively from school F?

1. 14 : 21
  2. 19 : 21
  3. 17 : 21
  4. 19 : 14
100. Ayush, Hina, Harbhajan and George are student friends studying in Delhi and plan to go on winter holiday some where in India. They can go to Rajasthan, Goa, Kerala, Odisha, Madhya Pradesh or any of the North Eastern States.  
Ayush is willing to go any where except North Eastern States. Harbhajan prefers not to go to Goa and Kerala. Hina wants to go either to Goa or Odisha. George does not mind as long as it is not Rajasthan. Which destination would be acceptable to all?
1. Goa
  2. Odisha
  3. Kerala
  4. Madhya Pradesh