

Solutions to JEE (Main)-2018

PART A— MATHEMATICS

1. If the curves $y^2 = 6x$, $9x^2 + by^2 = 16$ intersect each other at right angles, then the value of b is :

- (1) $\frac{9}{2}$ (2) 6
 (3) $\frac{7}{2}$ (4) 4

Sol.

(1) Let the point of intersection be (x_1, y_1) finding slope of both the curves at point of intersection for $y^2 = 6x$, $9x^2 + by^2 = 16$

$$2y \frac{dy}{dx} = 6, \quad m_1 = \frac{6}{2y_1}$$

$$18x + 2by \frac{dy}{dx} = 0, \quad m_2 = -\frac{18x_1}{2by_1}$$

$$m_1 m_2 = -1$$

$$\left(\frac{6}{2y_1}\right)\left(\frac{-18x_1}{2by_1}\right) = -1$$

$$\frac{(6)(-18)x_1}{(4b)(6x_1)} = -1 \Rightarrow b = \frac{9}{2}$$

2. Let \vec{u} be a vector coplanar with the vectors $\vec{a} = 2\hat{i} + 3\hat{j} - \hat{k}$ and $\vec{b} = \hat{j} + \hat{k}$. If \vec{u} is perpendicular to \vec{a} and $\vec{u} \cdot \vec{b} = 24$, then $|\vec{u}|^2$ is equal to :

- (1) 84 (2) 336
 (3) 315 (4) 256

Sol.

(2)

$$\vec{u} = \lambda_1 \vec{a} + \lambda_2 \vec{b}$$

$$\vec{u} \cdot \vec{a} = \lambda_1 \vec{a} \cdot \vec{a} + \lambda_2 \vec{a} \cdot \vec{b}$$

$$0 = \lambda_1 (4 + 9 + 1) + \lambda_2 (3 - 1)$$

$$\lambda_2 = -7\lambda_1$$

$$\vec{u} \cdot \vec{b} = \lambda_1 \vec{a} \cdot \vec{b} + \lambda_2 \vec{b} \cdot \vec{b}$$

$$24 = \lambda_1 (2) + (-7\lambda_1)(2)$$

$$24 = -12\lambda_1 \Rightarrow \lambda_1 = -2$$

$$\lambda_2 = 14$$

$$\vec{u} = -2(2\hat{i} + 3\hat{j} - \hat{k}) + 14(\hat{j} + \hat{k}) = -4\hat{i} + 8\hat{j} + 16\hat{k}$$

$$|\vec{u}|^2 = 336$$

3. For each $t \in \mathbb{R}$, let $[t]$ be the greatest integer less than or equal to t . Then $\lim_{x \rightarrow 0^+} x \left(\left[\frac{1}{x} \right] + \left[\frac{2}{x} \right] + \dots + \left[\frac{15}{x} \right] \right)$

- (1) does not exist (in \mathbb{R}) (2) is equal to 0
 (3) is equal to 15 (4) is equal to 120

Sol. (4)

$$\begin{aligned} & \lim_{x \rightarrow 0^+} x \left(\left[\frac{1}{x} \right] + \left[\frac{2}{x} \right] + \dots + \left[\frac{15}{x} \right] \right) \\ &= \lim_{x \rightarrow 0^+} x \left[\left(\frac{1}{x} + \frac{2}{x} + \dots + \frac{15}{x} \right) - \left(\left\{ \frac{1}{x} \right\} + \left\{ \frac{2}{x} \right\} + \dots + \left\{ \frac{15}{x} \right\} \right) \right] \\ &= \lim_{x \rightarrow 0^+} (1 + 2 + \dots + 15) - x \left(\left\{ \frac{1}{x} \right\} + \dots + \left\{ \frac{15}{x} \right\} \right) = 120 \end{aligned}$$

4. If L_1 is the line of intersection of the planes $2x - 2y + 3z - 2 = 0$, $x - y + z + 1 = 0$ and L_2 is the line of intersection of the planes $x + 2y - z - 3 = 0$, $3x - y + 2z - 1 = 0$, then the distance of the origin from the plane, containing the lines L_1 and L_2 , is :

- | | |
|---------------------------|---------------------------|
| (1) $\frac{1}{\sqrt{2}}$ | (2) $\frac{1}{4\sqrt{2}}$ |
| (3) $\frac{1}{3\sqrt{2}}$ | (4) $\frac{1}{2\sqrt{2}}$ |

Sol. (3)

Vectors along the given lines L_1, L_2 are

$$\hat{n}_1 = \begin{vmatrix} \hat{i} & \hat{j} & \hat{k} \\ 2 & -2 & 3 \\ 1 & -1 & 1 \end{vmatrix} = \hat{i} + \hat{j}$$

$$\text{and } \hat{n}_2 = \begin{vmatrix} \hat{i} & \hat{j} & \hat{k} \\ 1 & 2 & -1 \\ 3 & -1 & 2 \end{vmatrix} = 3\hat{i} - 5\hat{j} - 7\hat{k}$$

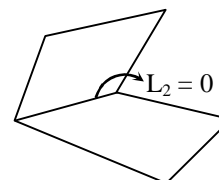
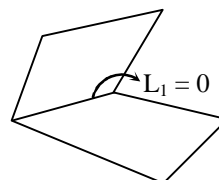

Putting $y = 0$ in 1st two equation

$$2x + 3z = 2$$

$$2x + 2z = -2$$

$$z = 4$$

Point on the plane is $(-5, 0, 4)$ and normal vector of required plane is

$$\begin{vmatrix} \hat{i} & \hat{j} & \hat{k} \\ 1 & 1 & 0 \\ 3 & -5 & -7 \end{vmatrix} = -7\hat{i} + 7\hat{j} - 8\hat{k}$$

Hence, equation of plane is $-7x + 7y - 8z - 3 = 0$

Perpendicular distance is $\frac{3}{\sqrt{162}} = \frac{1}{3\sqrt{2}}$

5. The value of $\int_{-\frac{\pi}{2}}^{\frac{\pi}{2}} \frac{\sin^2 x}{1+2^x} dx$ is :

- | | |
|---------------------|---------------------|
| (1) $\frac{\pi}{4}$ | (2) $\frac{\pi}{8}$ |
| (3) $\frac{\pi}{2}$ | (4) 4π |

Sol. (1)

$$\text{Let } I = \int_{-\frac{\pi}{2}}^{\frac{\pi}{2}} \frac{\sin^2 x}{1+2^x} dx$$

$$\Rightarrow I = \int_{-\frac{\pi}{2}}^{\frac{\pi}{2}} \frac{\sin^2 x}{1+2^{-x}} dx$$

$$\Rightarrow 2I = \int_{-\frac{\pi}{2}}^{\frac{\pi}{2}} \sin^2 x dx = \int_0^{\frac{\pi}{2}} 2 \sin^2 x dx$$

$$\Rightarrow 2I = \int_0^{\frac{\pi}{2}} (1 - \cos 2x) dx = \frac{\pi}{2}$$

$$\Rightarrow I = \frac{\pi}{4}$$

6. Let $g(x) = \cos x^2$, $f(x) = \sqrt{x}$, and α, β ($\alpha < \beta$) be the roots of the quadratic equation $18x^2 - 9\pi x + \pi^2 = 0$. Then the area (in sq. units) bounded by the curve $y = (g \circ f)(x)$ and the lines $x = \alpha$, $x = \beta$ and $y = 0$, is :

(1) $\frac{1}{2}(\sqrt{2}-1)$

(2) $\frac{1}{2}(\sqrt{3}-1)$

(3) $\frac{1}{2}(\sqrt{3}+1)$

(4) $\frac{1}{2}(\sqrt{3}-\sqrt{2})$

Sol. (2)

$$\text{Required area} = \int_{\frac{\pi}{6}}^{\frac{\pi}{3}} (\cos x) dx = \frac{\sqrt{3}-1}{2}$$

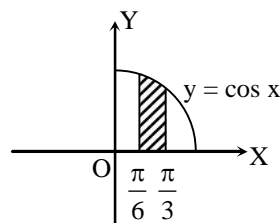

7. If sum of all the solutions of the equation $8 \cos x \left(\cos \left(\frac{\pi}{6} + x \right) \cos \left(\frac{\pi}{6} - x \right) - \frac{1}{2} \right) = 1$ in $[0, \pi]$ is $k \pi$, then k is equal to :

(1) $\frac{20}{9}$

(2) $\frac{2}{3}$

(3) $\frac{13}{9}$

(4) $\frac{8}{9}$

Sol. (3)

$$8 \cos x \left(\cos \left(\frac{\pi}{6} + x \right) \cos \left(\frac{\pi}{6} - x \right) - \frac{1}{2} \right) = 1$$

$$\Rightarrow 8 \cos x \left(\cos^2 \frac{\pi}{6} - \sin^2 x - \frac{1}{2} \right) = 1$$

$$\Rightarrow 6 \cos x - 8 \cos x \sin^2 x - 4 \cos x = 1$$

$$\Rightarrow 2 \cos x - 8 \cos x (1 - \cos^2 x) = 1$$

$$\Rightarrow 2 \cos 3x = 1 \Rightarrow \cos 3x = \frac{1}{2}$$

$$\Rightarrow 3x = 2n\pi \pm \frac{\pi}{3} \Rightarrow x = \frac{2n\pi}{3} \pm \frac{\pi}{9}$$

$$x = \frac{\pi}{9}, \frac{5\pi}{9}, \frac{7\pi}{9}$$

$$k\pi = \frac{13\pi}{9} \Rightarrow k = \frac{13}{9}$$

8. Let $f(x) = x^2 + \frac{1}{x^2}$ and $g(x) = x - \frac{1}{x}$, $x \in \mathbb{R} - \{-1, 0, 1\}$. If $h(x) = \frac{f(x)}{g(x)}$, then the local minimum value

of $h(x)$ is :

(1) $2\sqrt{2}$

(2) 3

(3) -3

(4) $-2\sqrt{2}$

Sol. (1)

$$f(x) = x^2 + \frac{1}{x^2}$$

$$g(x) = x - \frac{1}{x}$$

$$h(x) = \frac{f(x)}{g(x)} = \frac{x^2 + \frac{1}{x^2}}{x - \frac{1}{x}}$$

$$= \frac{\left(x - \frac{1}{x}\right)^2 + 2}{\left(x - \frac{1}{x}\right)}$$

$$h(x) = \left(x - \frac{1}{x}\right) + \frac{2}{x - \frac{1}{x}}$$

$$h'(x) = \left(1 + \frac{1}{x^2}\right) \left[1 - \frac{2}{\left(x - \frac{1}{x}\right)^2}\right]$$

$$\Rightarrow h'(x) = 0 \text{ at } x - \frac{1}{x} = \pm\sqrt{2}$$

$$x - \frac{1}{x} = \sqrt{2} \text{ point of local minima}$$

Hence, local minimum value is $2\sqrt{2}$

9. The integral $\int \frac{\sin^2 x \cos^2 x}{(\sin^5 x + \cos^3 x \sin^2 x + \sin^3 x \cos^2 x + \cos^5 x)^2} dx$ is equal to :

(1) $\frac{-1}{1 + \cot^3 x} + C$

(2) $\frac{1}{3(1 + \tan^3 x)} + C$

(3) $\frac{-1}{3(1 + \tan^3 x)} + C$

(4) $\frac{1}{1 + \cot^3 x} + C$

(where C is a constant of integration)

Sol. (3)

$$\int \frac{\sin^2 x \cos^2 x}{(\sin^5 x + \cos^3 x \sin^2 x + \sin^3 x \cos^2 x + \cos^5 x)^2} dx$$

$$= \int \frac{\sin^2 x \cos^2 x}{(\sin^3 x + \cos^3 x)^2} dx$$

$$= \int \frac{\tan^2 x \cdot \sec^2 x}{(1 + \tan^3 x)^2} dx$$

put $1 + \tan^3 x = t$

$$= \frac{1}{3} \int \frac{dt}{t^2} \Rightarrow -\frac{1}{3t} + c$$

$$= -\frac{1}{3(1 + \tan^3 x)} + c$$

10. A bag contains 4 red and 6 black balls. A ball is drawn at random from the bag, its colour is observed and this ball along with two additional balls of the same colour are returned to the bag. If now a ball is drawn at random from the bag, then the probability that this drawn ball is red, is :

(1) $\frac{3}{4}$

(2) $\frac{3}{10}$

(3) $\frac{2}{5}$

(4) $\frac{1}{5}$

Sol. (3)

Initially 4 Red balls and 6-Black balls

$$\text{Required probability} = \frac{4}{10} \times \frac{6}{12} + \frac{6}{10} \times \frac{4}{12} = \frac{2}{5}$$

11. Let the orthocentre and centroid of a triangle be A(-3, 5) and B(3, 3) respectively. If C is the circumcentre of this triangle, then the radius of the circle having line segment AC as diameter, is :

(1) $\frac{3\sqrt{5}}{2}$

(2) $\sqrt{10}$

(3) $2\sqrt{10}$

(4) $3\sqrt{\frac{5}{2}}$

Sol. (4)

Orthocentre A (-3, 5) centroid B (3, 3)

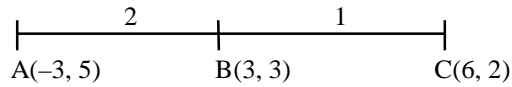

$$AC = 3\sqrt{10}$$

$$\text{Radius} = \frac{3\sqrt{10}}{2} = 3\sqrt{\frac{5}{2}}$$

12. If the tangent at (1, 7) to the curve $x^2 = y - 6$ touches the circle $x^2 + y^2 + 16x + 12y + c = 0$ then the value of c is :

- (1) 95 (2) 195
(3) 185 (4) 85

Sol. (1)

Equation tangent at (1, 7)

$$\Rightarrow 2x - y + 5 = 0$$

perpendicular (-8, -6) to line

$$= \frac{|2(-8) - (-6) + 5|}{\sqrt{5}} = \sqrt{8^2 + 6^2 - c}$$

$$\Rightarrow \sqrt{5} = \sqrt{8^2 + 6^2 - c}$$
$$c = 95.$$

13. If $\alpha, \beta \in \mathbb{C}$ are the distinct roots, of the equation $x^2 - x + 1 = 0$, then $\alpha^{101} + \beta^{107}$ is equal to :

- (1) 2 (2) -1
(3) 0 (4) 1

Sol. (4)

$$x^2 - x + 1 = 0$$

Roots $(-\omega, -\omega^2)$, $\alpha = -\omega$, $\beta = -\omega^2$

$$\alpha^{101} + \beta^{107} = (-\omega)^{101} + (-\omega^2)^{107} = 1$$

14. PQR is a triangular park with $PQ = PR = 200$ m. A T.V. tower stands at the mid-point of QR. If the angles of elevation of the top of the tower at P, Q and R are respectively 45° , 30° and 30° , then the height of the tower (in m) is :

- (1) $50\sqrt{2}$ (2) 100
(3) 50 (4) $100\sqrt{3}$

Sol. (2)

Let $ST = h$ (height of tower)

$$PT = ST = h$$

$$\frac{ST}{QT} = \tan 30^\circ$$

$$QT = h\sqrt{3}$$

$$\text{Now } PT^2 + QT^2 = 200^2$$

$$4h^2 = 200^2$$

$$h = 100$$

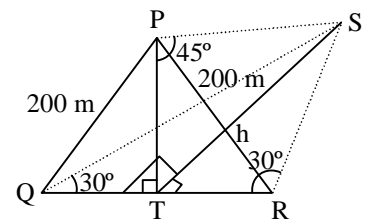

15. If $\sum_{i=1}^9 (x_i - 5) = 9$ and $\sum_{i=1}^9 (x_i - 5)^2 = 45$, then the standard deviation of the 9 items x_1, x_2, \dots, x_9 is :
- (1) 3 (2) 9
(3) 4 (4) 2

Sol. (4)

$$x_i - 5 = y_i$$

$$\sigma = \sqrt{\frac{\sum y_i^2}{9} - \left(\frac{\sum y_i}{9}\right)^2} = \sqrt{\frac{45}{9} - \left(\frac{9}{9}\right)^2} = 2$$

16. The sum of the co-efficients of all odd degree terms in the expansion of $(x + \sqrt{x^3 - 1})^5 + (x - \sqrt{x^3 - 1})^5$, ($x > 1$) is :
- (1) 2 (2) -1
(3) 0 (4) 1

Sol. (1)

$$= 2 \left({}^5C_0 x^5 + {}^5C_2 x^3 (x^3 - 1) + {}^5C_4 x (x^3 - 1)^2 \right)$$

$$= 2 \left(x^5 + 10(x^6 - x^3) + 5(x)(x^6 + 1 - 2x^3) \right)$$

$$\text{Sum of coefficient of odd powers} = 2(1 - 10 + 10) = 2.$$

17. Tangents are drawn to the hyperbola $4x^2 - y^2 = 36$ at the points P and Q. If these tangents intersect at the point T(0, 3) then the area (in sq. units) of ΔPTQ is :
- (1) $36\sqrt{5}$ (2) $45\sqrt{5}$
(3) $54\sqrt{3}$ (4) $60\sqrt{3}$

Sol. (2)

Chord of contact is $y = -12$

$$4x^2 = y^2 + 36 \Rightarrow x^2 = 45$$

$$\Delta = \frac{1}{2} \times 6\sqrt{5} \times 15 = 45\sqrt{5}$$

18. From 6 different novels and 3 different dictionaries, 4 novels and 1 dictionary are to be selected and arranged in a row on a shelf so that the dictionary is always in the middle. The number of such arrangements is :
- (1) at least 750 but less than 1000 (2) at least 1000
(3) less than 500 (4) at least 500 but less than 750

Sol. (2)

Dictionary can be chosen in ${}^3C_1 = 3$ ways

Novels can be arranged in ${}^6C_4 4! = 360$ ways

$$N = 3 \times 360 = 1080$$

19. If the system of linear equations

$$x + ky + 3z = 0$$

$$3x + ky - 2z = 0$$

$$2x + 4y - 3z = 0$$

has a non-zero solution (x, y, z) , then $\frac{xz}{y^2}$ is equal to :

(1) 30

(2) -10

(3) 10

(4) -30

Sol.

(3)

For non-zero solution $D = 0$

$$\begin{vmatrix} 1 & k & 3 \\ 3 & k & -2 \\ 2 & 4 & -3 \end{vmatrix} = 0$$

$$\Rightarrow 1(-3k + 8) - k(-9 + 4) + 3(12 - 2k) = 0$$

$$\Rightarrow -3k + 8 + 5k + 36 - 6k = 0$$

$$\Rightarrow -4k + 44 = 0$$

$$k = 11$$

hence equations are $x + 11y + 3z = 0$

$$3x + 11y - 2z = 0$$

$$\text{and } 2x + 4y - 3z = 0$$

let $z = t$

$$\text{then we get, } x = \frac{5}{2}t \text{ and } y = -\frac{t}{2}$$

$$\text{thus, } \frac{xz}{y^2} = \frac{\left(\frac{5}{2}t\right)(t)}{\frac{t^2}{4}} = 10$$

20. If $\begin{vmatrix} x-4 & 2x & 2x \\ 2x & x-4 & 2x \\ 2x & 2x & x-4 \end{vmatrix} = (A + Bx)(x - A)^2$, then the ordered pair (A, B) is equal to :

(1) (4, 5)

(2) (-4, -5)

(3) (-4, 3)

(4) (-4, 5)

Sol.

(4)

$$(5x - 4) \begin{vmatrix} 1 & 2x & 2x \\ 1 & x-4 & 2x \\ 1 & 2x & x-4 \end{vmatrix}$$

$$= (5x - 4) \begin{vmatrix} 1 & 2x & 2x \\ 0 & -(x+4) & 0 \\ 0 & 0 & -(x+4) \end{vmatrix}$$

$$= (5x - 4)(x + 4)^2 = (A + Bx)(x - A)^2$$

$$\Rightarrow A = -4, B = 5$$

21. Two sets A and B are as under :
 $A = \{(a, b) \in \mathbb{R} \times \mathbb{R} : |a - 5| < 1 \text{ and } |b - 5| < 1\}$;
 $B = \{(a, b) \in \mathbb{R} \times \mathbb{R} : 4(a - 6)^2 + 9(b - 5)^2 \leq 36\}$. Then :

- (1) neither $A \subset B$ nor $B \subset A$ (2) $B \subset A$
 (3) $A \subset B$ (4) $A \cap B = \phi$ (an empty set)

Sol. (3)

$$A = \{(a, b) : a \in (4, 6), b \in (4, 6)\}$$

$$B = \{(a, b) : 4(a - 6)^2 + 9(b - 5)^2 \leq 36\}$$

$$\Rightarrow \frac{(a - 6)^2}{9} + \frac{(b - 5)^2}{4} \leq 1$$

$$\Rightarrow A \subset B$$

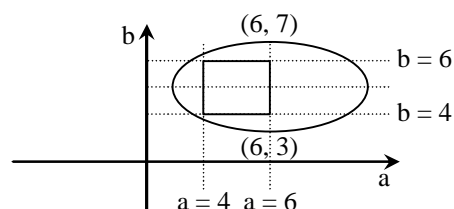

22. Tangent and normal are drawn at $P(16, 16)$ on the parabola $y^2 = 16x$, which intersect the axis of the parabola at A and B, respectively. If C is the centre of the circle through the points P, A and B and $\angle CPB = \theta$, then a value of $\tan \theta$ is :

- (1) $\frac{4}{3}$ (2) $\frac{1}{2}$
 (3) 2 (4) 3

Sol. (3)

Focus will be centre of Circumcircle of ΔPAB

$$B : (24, 0)$$

$$C : (4, 0)$$

$$m_{CP} = \frac{16}{12} = \frac{4}{3}, m_{PB} = -2$$

$$\tan \theta = \left| \frac{\frac{4}{3} + 2}{1 - \frac{8}{3}} \right| = 2$$

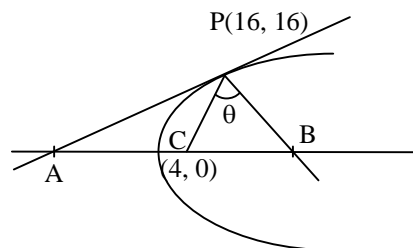

23. Let $S = \{t \in \mathbb{R} : f(x) = |x - \pi| \cdot (e^{|x|} - 1) \sin|x| \text{ is not differentiable at } t\}$. Then the set S is equal to :

- (1) $\{0, \pi\}$ (2) ϕ (an empty set)
 (3) $\{0\}$ (4) $\{\pi\}$

Sol. (2)

$$S = \{t : \mathbb{R} \in : f(x) = |x - \pi| \cdot (e^{|x|} - 1) \sin|x| \text{ is not diff. at } t\}$$

$$f(x) = |x - \pi| \cdot (e^{|x|} - 1) \cdot \sin|x|$$

$$\text{at } x = 0, \pi$$

$$f'(0^+) = \lim_{h \rightarrow 0^+} \left(\frac{|h - \pi| (e^{|h|} - 1) \sin|h|}{h} \right) = \lim_{h \rightarrow 0^+} \left(\frac{(\pi - h)(e^h - 1) \cdot \sin h}{h} \right) = 0$$

$$f'(0^-) = \lim_{h \rightarrow 0^+} \left(\frac{|-h - \pi| (e^{|-h|} - 1) \sin|-h|}{-h} \right) = 0$$

$$f'(\pi^+) = \lim_{h \rightarrow 0^+} \left(\frac{|h| \cdot (e^{|\pi+h|} - 1) \sin|\pi+h|}{h} \right) = \lim_{h \rightarrow 0^+} \left(\frac{-h(e^{\pi+h} - 1) \cdot \sinh}{h} \right) = 0$$

$$f(\pi^-) = \lim_{h \rightarrow 0^+} \left(\frac{|-h| \cdot (e^{|\pi-h|} - 1) \sinh}{-h} \right) = 0$$

$f(x)$ is diff. for all $x \in \mathbb{R}$

24. The Boolean expression $\sim(p \vee q) \vee (\sim p \wedge q)$ is equivalent to :
- (1) $\sim q$ (2) $\sim p$
 (3) p (4) q

Sol. (2)
 $(\sim p \wedge \sim q) \vee (\sim p \wedge q) = \sim p \wedge (\sim q \vee q) = \sim p$

Alternate solution

| P | q | $p \vee q$ | $\sim p$ | $\sim p \wedge q$ | $\sim(p \vee q)$ | $\sim(p \vee q) \vee (\sim p \wedge q)$ |
|---|---|------------|----------|-------------------|------------------|---|
| T | T | T | F | F | F | F |
| T | F | T | F | F | F | F |
| F | T | T | T | T | F | T |
| F | F | F | T | F | T | T |

25. A straight line through a fixed point (2, 3) intersects the coordinate axes at distinct points P and Q. If O is the origin and the rectangle OPRQ is completed, then the locus of R is :
- (1) $3x + 2y = 6xy$ (2) $3x + 2y = 6$
 (3) $2x + 3y = xy$ (4) $3x + 2y = xy$

Sol. (4)
 Let the point R(a, b)

then equation of line be $\frac{x}{a} + \frac{y}{b} = 1$

$$\Rightarrow \frac{2}{a} + \frac{3}{b} = 1$$

Locus of R is $\frac{2}{x} + \frac{3}{y} = 1$

i.e. $2y + 3x = xy$

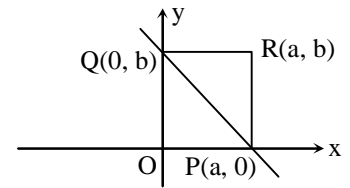

26. Let A be the sum of the first 20 terms and B be the sum of the first 40 terms of the series
 $1^2 + 2 \cdot 2^2 + 3^2 + 2 \cdot 4^2 + 5^2 + 2 \cdot 6^2 + \dots$

If $B - 2A = 100\lambda$, then λ is equal to :

- (1) 496 (2) 232
 (3) 248 (4) 464

Sol. (3)
 $A = (1^2 + 2^2 + 3^2 + \dots + 20^2) + (2^2 + 4^2 + \dots + 20^2)$
 $= (1^2 + 2^2 + 3^2 + \dots + 20^2) + 2^2(1^2 + 2^2 + 3^2 + \dots + 10^2)$
 $= \frac{20 \times 21 \times 41}{6} + \frac{4 \times 10 \times 11 \times 21}{6}$
 $= 4410$
 $B = (1^2 + 2^2 + 3^2 + \dots + 40^2) + (2^2 + 4^2 + 6^2 + \dots + 40^2)$
 $= 1^2 + 2^2 + 3^2 + \dots + 40^2 + 4(1^2 + 2^2 + \dots + 20^2)$
 $= \frac{40 \times 41 \times 81}{6} + \frac{4 \times 20 \times 21 \times 41}{6}$
 $= 33620$
 $B - 2A = 33620 - 8820 = 24800$
 $= 100\lambda$
 $\Rightarrow \lambda = 248$

Alternate solution

$$S_n = \frac{n(n+1)^2}{2}, n \text{ is even.}$$

$$\therefore B - 2A = 40 \cdot \frac{41^2}{2} - 40 \cdot \frac{21^2}{2}$$

$$\Rightarrow 100\lambda = 400 \times 62 \Rightarrow \lambda = 248$$

27. Let $y = y(x)$ be the solution of the differential equation $\sin x \frac{dy}{dx} + y \cos x = 4x$, $x \in (0, \pi)$. If $y\left(\frac{\pi}{2}\right) = 0$,

then $y\left(\frac{\pi}{6}\right)$ is equal to :

(1) $-\frac{4}{9}\pi^2$

(2) $\frac{4}{9\sqrt{3}}\pi^2$

(3) $\frac{-8}{9\sqrt{3}}\pi^2$

(4) $-\frac{8}{9}\pi^2$

Sol. (4)

$$\frac{d}{dx}(y \sin x) = 4x$$

$$\Rightarrow y \sin x = 4 \frac{x^2}{2} + c$$

$$y \sin x = 2x^2 + c$$

$$\text{given } y\left(\frac{\pi}{2}\right) = 0$$

$$c = -\pi^2/2$$

$$\text{Thus } y \sin x = 2x^2 - \pi^2/2$$

$$\text{now } y(\pi/6) = -\frac{8}{9}\pi^2$$

28. The length of the projection of the line segment joining the points $(5, -1, 4)$ and $(4, -1, 3)$ on the plane, $x + y + z = 7$ is :

(1) $\frac{\sqrt{2}}{\sqrt{3}}$

(2) $\frac{2}{\sqrt{3}}$

(3) $\frac{2}{3}$

(4) $\frac{1}{3}$

Sol. (1)

$$\text{D.R's of } AB = (1, 0, 1)$$

$$\text{D.R's of normal to plane} = (1, 1, 1)$$

$$\cos\left(\frac{\pi}{2} - \theta\right) = \frac{1+1}{\sqrt{2}\sqrt{3}} = \frac{\sqrt{2}}{\sqrt{3}} = \sin \theta$$

$$AB = \sqrt{2}$$

$$\text{Length of projection} = AB \cos \theta = \frac{\sqrt{2}}{3}$$

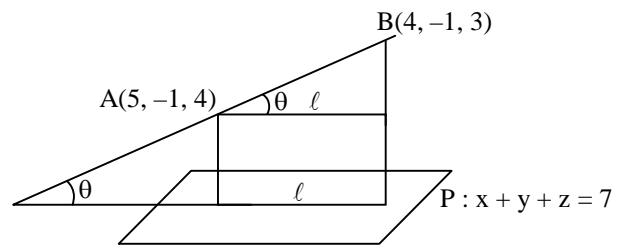

PART B – PHYSICS

(ALL THE GRAPHS/DIAGRAMS GIVEN ARE SCHEMATIC AND NOT DRAWN TO SCALE)

31. Three concentric metal shells A, B and C of respective radii a , b and c ($a < b < c$) have surface charge densities $+\sigma$, $-\sigma$ and $+\sigma$ respectively. The potential of shell B is :

| | |
|--|--|
| (1) $\frac{\sigma}{\epsilon_0} \left[\frac{b^2 - c^2}{c} + a \right]$ | (2) $\frac{\sigma}{\epsilon_0} \left[\frac{a^2 - b^2}{a} + c \right]$ |
| (3) $\frac{\sigma}{\epsilon_0} \left[\frac{a^2 - b^2}{b} + c \right]$ | (4) $\frac{\sigma}{\epsilon_0} \left[\frac{b^2 - c^2}{b} + a \right]$ |

Sol.

(3)

$$V_B = V_{B(I)} + V_{B(II)} + V_{B(III)}$$

$$V_B = \frac{K4\pi a^2 \sigma}{b} + \frac{K4\pi b^2 (-\sigma)}{b} + \frac{K4\pi c^2 (\sigma)}{c}$$

$$= \frac{\sigma}{\epsilon_0} \left(\frac{a^2 - b^2}{b} + c \right)$$

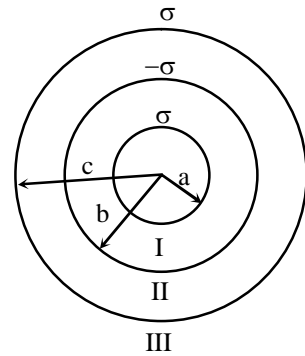

32. Seven identical circular planar disks, each of mass M and radius R are welded symmetrically as shown. The moment of inertia of the arrangement about the axis normal to the plane and passing through the point P is :

| | |
|--------------------------|-------------------------|
| (1) $\frac{181}{2} MR^2$ | (2) $\frac{19}{2} MR^2$ |
| (3) $\frac{55}{2} MR^2$ | (4) $\frac{73}{2} MR^2$ |

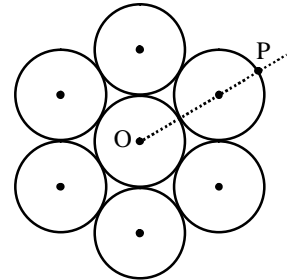

Sol.

(1)

$$I = I_{cm} + 7M(3R)^2$$

$$= \left[\frac{MR^2}{2} + 6 \times \left\{ \frac{MR^2}{2} + M(2R)^2 \right\} \right] + 7M(3R)^2 = \frac{181 MR^2}{2}$$

33. From a uniform circular disc of radius R and mass $9M$, a small disc of radius $\frac{R}{3}$ is removed as shown in the figure. The moment of inertia of the remaining disc about an axis perpendicular to the plane of the disc and passing through centre of disc is :

| | |
|-------------------------|---------------|
| (1) $\frac{37}{9} MR^2$ | (2) $4 MR^2$ |
| (3) $\frac{40}{9} MR^2$ | (4) $10 MR^2$ |

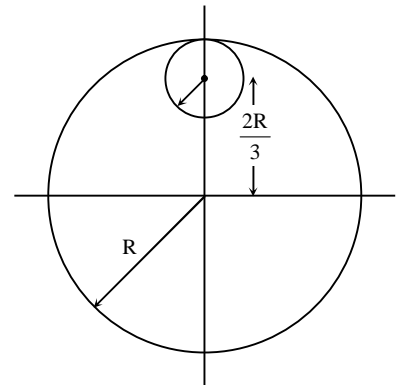

Sol. (2)

$$I = \frac{9MR^2}{2} - \left[\frac{M}{2} \left(\frac{R}{3} \right)^2 + M \left(\frac{2R}{3} \right)^2 \right] = 4MR^2$$

34. The reading of the ammeter for a silicon diode in the given circuit is :

- (1) 13.5 mA
(3) 15 mA

- (2) 0
(4) 11.5 mA

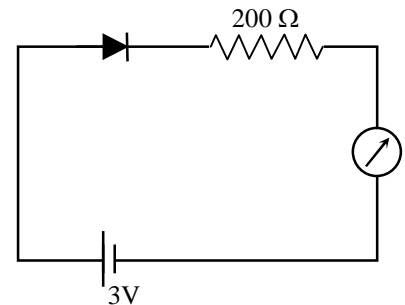

Sol. (4)

$$I = \frac{3 - 0.7}{200} \text{ A} = 11.5 \text{ mA}$$

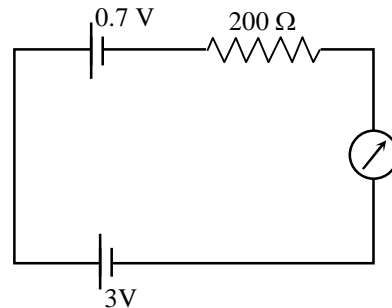

35. Unpolarized light of intensity I passes through an ideal polarizer A. Another identical polarizer B is placed behind A. The intensity of light beyond B is found to be $\frac{I}{2}$. Now another identical polarizer C is placed

between A and B. The intensity beyond B is now found to be $\frac{I}{8}$. The angle between polarizer A and C is :

- (1) 60°
(3) 30°

- (2) 0°
(4) 45°

Sol. (4)

$$\frac{I}{8} = \frac{I}{2} (\cos^2 \theta)^2$$

$$\Rightarrow \cos \theta = \frac{1}{\sqrt{2}}$$

$$\Rightarrow \theta = 45^\circ$$

36. For an RLC circuit driven with voltage of amplitude v_m and frequency $\omega_0 = \frac{1}{\sqrt{LC}}$ the current exhibits resonance. The quality factor, Q is given by :

(1) $\frac{CR}{\omega_0}$

(2) $\frac{\omega_0 L}{R}$

(3) $\frac{\omega_0 R}{L}$

(4) $\frac{R}{(\omega_0 C)}$

Sol. (2)

$$Q = \frac{\omega_1 - \omega_2}{\omega_0} = \frac{1}{R} \sqrt{\frac{L}{C}} = \frac{\omega_0 L}{R} \quad [\text{here } \omega_0^2 = \frac{1}{LC}]$$

Alternate solution

$\frac{\omega_0 L}{R}$ is the only dimensionless quantity, hence must be the quality factor.

37. Two masses $m_1 = 5 \text{ kg}$ and $m_2 = 10 \text{ kg}$, connected by an inextensible string over a frictionless pulley, are moving as shown in the figure. The coefficient of friction of horizontal surface is 0.15. The minimum weight m that should be put on top of m_2 to stop the motion is :

- (1) 10.3 kg (2) 18.3 kg
(3) 27.3 kg (4) 43.3 kg

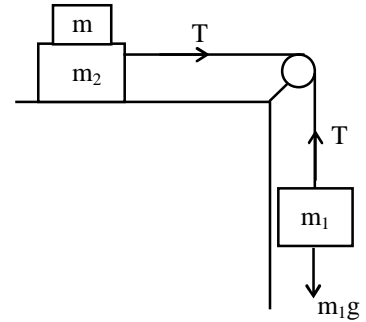

Sol. (3)

$$T = 5g$$

$$\mu(10 + m)g \geq 5g$$

$$10 + m \geq \frac{5}{0.15}$$

$$m \geq 23.33 \text{ kg}$$

The minimum value from the options, satisfying the above condition is, $m = 27.3 \text{ kg}$

38. In a collinear collision, a particle with an initial speed v_0 strikes a stationary particle of the same mass. If the final total kinetic energy is 50% greater than the original kinetic energy, the magnitude of the relative velocity between the two particles, after collision, is :

- (1) $\frac{v_0}{\sqrt{2}}$ (2) $\frac{v_0}{4}$
(3) $\sqrt{2} v_0$ (4) $\frac{v_0}{2}$

Sol. (3)

$$k_f = 1.5 k_i$$

$$v_1^2 + v_2^2 = 1.5v_0^2$$

From conservation of momentum

$$v_1 + v_2 = v_0$$

from (i) and (ii)

$$2v_1v_2 = -0.5 v_0^2$$

$$\text{So, } v_2 - v_1 = \sqrt{v_2^2 + v_1^2 - 2v_1v_2} = \sqrt{1.5v_0^2 + 0.5v_0^2} = \sqrt{2} v_0$$

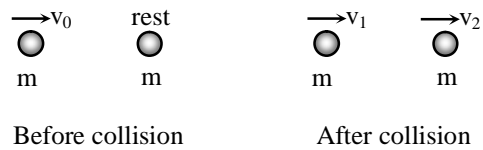

39. A particle is moving with a uniform speed in a circular orbit of radius R in a central force inversely proportional to the n^{th} power of R . If the period of rotation of the particle is T , then :

- (1) $T \propto R^{n/2}$ (2) $T \propto R^{3/2}$ for any n .
(3) $T \propto R^{\frac{n}{2}+1}$ (4) $T \propto R^{(n+1)/2}$

Sol. (4)

$$F \propto \frac{1}{R^n}$$

$$v \propto \frac{1}{R^{\frac{n-1}{2}}}$$

$$T = \frac{2\pi R}{v}$$

$$T \propto R^{1+\frac{n-1}{2}}$$

$$T \propto R^{\frac{n+1}{2}}$$

40. Two batteries with e.m.f 12 V and 13 V are connected in parallel across a load resistor of 10 Ω . The internal resistances of the two batteries are 1 Ω and 2 Ω respectively. The voltage across the load lies between :

(1) 11.7 V and 11.8 V

(2) 11.6 V and 11.7 V

(3) 11.5 V and 11.6 V

(4) 11.4 V and 11.5 V

Sol. (3)

The circuit may be drawn as shown in the figure.

$$\epsilon_{eq} = \frac{\sum \epsilon_i}{\sum \frac{1}{r_i}} = 11.56 \text{ V}$$

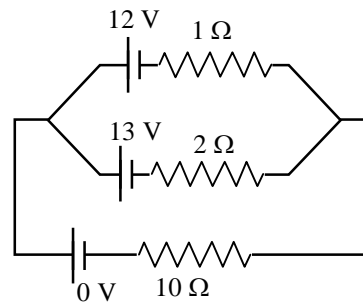

41. In an a.c. circuit, the instantaneous e.m.f. and current are given by

$$e = 100 \sin 30 t$$

$$i = 20 \sin \left(30 t - \frac{\pi}{4} \right)$$

In one cycle of a.c., the average power consumed by the circuit and the wattless current are, respectively :

(1) 50, 0

(2) 50, 10

(3) $\frac{1000}{\sqrt{2}}$, 10

(4) $\frac{50}{\sqrt{2}}$, 0

Sol. (3)

$$\langle P \rangle = \frac{\epsilon_0 I_0 \cos \phi}{2} = \frac{(100)(20) \cos \frac{\pi}{4}}{2} = \frac{1000}{\sqrt{2}} \text{ watt}$$

$$\text{Wattless current} = I_{rms} \sin \phi = \frac{20}{\sqrt{2}} \frac{1}{\sqrt{2}} = 10 \text{ A}$$

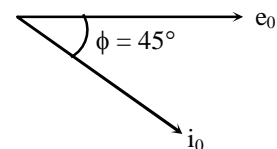

42. An EM wave from air enters a medium. The electric fields are

$$\vec{E}_1 = E_{01} \hat{x} \cos \left[2\pi \nu \left(\frac{z}{c} - t \right) \right] \text{ in air and}$$

$\vec{E}_2 = E_{02} \hat{x} \cos [k(2z - ct)]$ in medium, where the wave number k and frequency ν refer to their values in air. The medium is non-magnetic. If ϵ_{r_1} and ϵ_{r_2} refer to relative permittivities of air and medium respectively, which of the following options is **correct** ?

- (1) $\frac{\epsilon_{r_1}}{\epsilon_{r_2}} = \frac{1}{2}$ (2) $\frac{\epsilon_{r_1}}{\epsilon_{r_2}} = 4$
 (3) $\frac{\epsilon_{r_1}}{\epsilon_{r_2}} = 2$ (4) $\frac{\epsilon_{r_1}}{\epsilon_{r_2}} = \frac{1}{4}$

Sol. (4)

$$\frac{v_{\text{air}}}{v_{\text{med}}} = \frac{c}{c/2} = 2 = \frac{\sqrt{\mu_0 \epsilon_0 \mu_{r_2} \epsilon_{r_2}}}{\sqrt{\mu_0 \epsilon_0 \mu_{r_1} \epsilon_{r_1}}}$$

$$\frac{\epsilon_{r_1}}{\epsilon_{r_2}} = \frac{1}{4}$$

43. A telephonic communication service is working at carrier frequency of 10 GHz. Only 10% of it is utilized for transmission. How many telephonic channels can be transmitted simultaneously if each channel requires a bandwidth of 5 kHz ?

- (1) 2×10^6 (2) 2×10^3
 (3) 2×10^4 (4) 2×10^5

Sol. (4)

$$\text{No. of telephonic channels that can be transmitted simultaneously} = \frac{0.1 \times 10 \times 10^9}{5 \times 10^3} = 2 \times 10^5$$

44. A granite rod of 60 cm length is clamped at its middle point and is set into longitudinal vibrations. The density of granite is $2.7 \times 10^3 \text{ kg/m}^3$ and its Young's modulus is $9.27 \times 10^{10} \text{ Pa}$. What will be the fundamental frequency of the longitudinal vibrations ?

- (1) 7.5 kHz (2) 5 kHz
 (3) 2.5 kHz (4) 10 kHz

Sol. (2)

$$\text{Wave velocity } (v) = \sqrt{\frac{Y}{\rho}} = 5.86 \times 10^3 \text{ m/s}$$

For fundamental mode, $\lambda = 1.2 \text{ m}$

$$\therefore \text{fundamental frequency} = \frac{v}{\lambda} = 4.88 \text{ kHz} \approx 5 \text{ kHz}$$

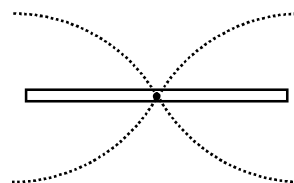

45. It is found that if a neutron suffers an elastic collinear collision with deuterium at rest, fractional loss of its energy is p_d ; while for its similar collision with carbon nucleus at rest, fractional loss of energy is p_c . The values of p_d and p_c are respectively :

- (1) (0, 1) (2) (.89, .28)
 (3) (.28, .89) (4) (0, 0)

Sol. (2)

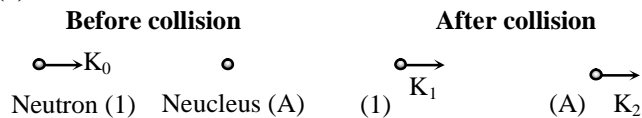

$$\therefore \sqrt{K_0} = \sqrt{K_1} + \sqrt{AK_2} \quad (\text{from conservation of momentum})$$

and $K_0 = K_1 + K_2$ (for elastic collision)

So after solving

$$(1 + A) \frac{K_1}{K_0} - 2\sqrt{\frac{K_1}{K_0}} = (A - 1)$$

For Deuterium, $A = 2$, $1 - \frac{K_1}{K_0} = 0.89$

For Carbon, $A = 12$, $1 - \frac{K_1}{K_0} = 0.28$

46. The density of a material in the shape of a cube is determined by measuring three sides of the cube and its mass. If the relative errors in measuring the mass and length are respectively 1.5% and 1%, the maximum error in determining the density is:

- | | |
|----------|----------|
| (1) 6% | (2) 2.5% |
| (3) 3.5% | (4) 4.5% |

Sol. (4)

$$\frac{\Delta\rho}{\rho} \times 100 = \frac{\Delta m}{m} \times 100 + \frac{3 \times \Delta a}{a} \times 100$$

$$= 4.5\%$$

47. Two moles of an ideal monoatomic gas occupies a volume V at 27°C . The gas expands adiabatically to a volume $2V$. Calculate (a) the final temperature of the gas and (b) change in its internal energy.

- | | |
|---------------|-------------|
| (1) (a) 195 K | (b) 2.7 kJ |
| (2) (a) 189 K | (b) 2.7 kJ |
| (3) (a) 195 K | (b) -2.7 kJ |
| (4) (a) 189 K | (b) -2.7 kJ |

Sol. (4)

$$T_1 V_1^{\gamma-1} = T_2 V_2^{\gamma-1}$$

$$\Rightarrow T_2 = 189 \text{ K}$$

$$\Delta U = n C_v \Delta T = -2.7 \text{ kJ}$$

48. A solid sphere of radius r made of a soft material of bulk modulus K is surrounded by a liquid in a cylindrical container. A massless piston of area a floats on the surface of the liquid, covering entire cross section of cylindrical container. When a mass m is placed on the surface of the piston to compress the

liquid, the fractional decrement in the radius of the sphere, $\left(\frac{dr}{r}\right)$, is:

- | | |
|----------------------|----------------------|
| (1) $\frac{mg}{Ka}$ | (2) $\frac{Ka}{mg}$ |
| (3) $\frac{Ka}{3mg}$ | (4) $\frac{mg}{3Ka}$ |

Sol. (4)

$$\frac{\Delta V}{V} = \frac{3\Delta r}{r}$$
$$K = \frac{P}{\Delta V/V}$$
$$\Rightarrow \frac{\Delta r}{r} = \frac{mg}{3Ka}$$

49. A parallel plate capacitor of capacitance 90 pF is connected to a battery of emf 20 V. If a dielectric material of dielectric constant $K = \frac{5}{3}$ is inserted between the plates, the magnitude of the induced charge will be :

- (1) 0.9 n C (2) 1.2 n C
(3) 0.3 n C (4) 2.4 n C

Sol. (2)

$$Q = KCV$$
$$Q_{\text{induced}} = Q(1 - 1/K)$$
$$\Rightarrow Q_{\text{induced}} = 1.2 \text{ n C}$$

50. The dipole moment of a circular loop carrying a current I, is m and the magnetic field at the centre of the loop is B_1 . When the dipole moment is doubled by keeping the current constant, the magnetic field at the centre of the loop is B_2 . The ratio $\frac{B_1}{B_2}$ is:

- (1) $\frac{1}{\sqrt{2}}$ (2) 2
(3) $\sqrt{3}$ (4) $\sqrt{2}$

Sol. (4)

$$m = I \times \pi r^2$$
$$2m = I \times \pi (r')^2$$
$$\Rightarrow r' = \sqrt{2}r$$
$$B = \frac{\mu_0 I}{2\pi r} \Rightarrow \frac{B_1}{B_2} = \frac{r'}{r} = \sqrt{2}$$

51. An electron from various excited states of hydrogen atom emit radiation to come to the ground state. Let λ_n, λ_g be the de Broglie wavelength of the electron in the n^{th} state and the ground state respectively. Let Λ_n be the wavelength of the emitted photon in the transition from the n^{th} state to the ground state. For large n, (A, B are constants)

- (1) $\Lambda_n^2 \approx \lambda$ (2) $\Lambda_n \approx A + \frac{B}{\lambda_n^2}$
(3) $\Lambda_n \approx A + B\lambda_n$ (4) $\Lambda_n^2 \approx A + B\lambda_n^2$

Sol. (2)

$$2\pi r = n\lambda_n$$
$$\lambda_n = \frac{2\pi r}{n} = \frac{2\pi r_0 n^2}{n} = 2\pi r_0 n \quad \dots(1)$$

$$\frac{1}{\Lambda_n} = R \left\{ \frac{1}{1^2} - \frac{1}{n^2} \right\}$$

$$\Lambda_n = \frac{1}{R} \left\{ 1 + \frac{1}{n^2 - 1} \right\}$$

$$\Lambda_n = \frac{1}{R} \left\{ 1 + \frac{1}{n^2} \right\} \quad (n \gg 1) \quad \dots(2)$$

From equation (1) and (2) $\Lambda_n = \frac{1}{R} \left\{ 1 + \frac{4\pi^2 r_0^2}{\lambda_n^2} \right\} = A + \frac{B}{\lambda_n^2}$

52. The mass of a hydrogen molecule is 3.32×10^{-27} kg. If 10^{23} hydrogen molecules strike, per second, a fixed wall of area 2 cm^2 at an angle of 45° to the normal, and rebound elastically with a speed of 10^3 m/s, then the pressure on the wall is nearly:
- (1) $4.70 \times 10^2 \text{ N/m}^2$ (2) $2.35 \times 10^3 \text{ N/m}^2$
 (3) $4.70 \times 10^3 \text{ N/m}^2$ (4) $2.35 \times 10^2 \text{ N/m}^2$

Sol.

(2)

$$P = \frac{(2mv \cos 45^\circ)n}{A} \quad (P \rightarrow \text{Pressure, } A \rightarrow \text{Area})$$

$$= \frac{2 \times 3.32 \times 10^{-27} \times 10^3 \times \frac{1}{\sqrt{2}} \times 10^{23}}{2 \times 10^{-4}}$$

$$= 2.35 \times 10^3 \text{ N/m}^2$$

53. All the graphs below are intended to represent the same motion. One of them does it incorrectly. Pick it up.

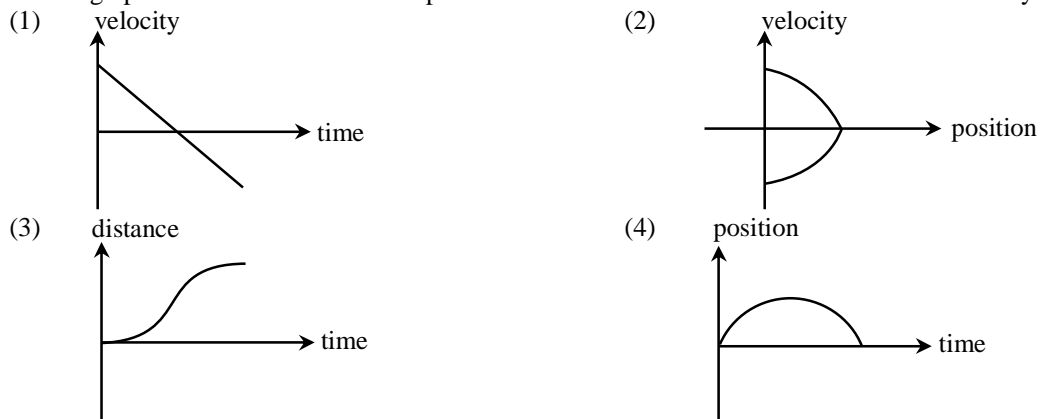

Sol.

(3) In graph '3' initial slope is zero which is not possible, since initial velocity is non zero in all other three graphs.

54. An electron, a proton and an alpha particle having the same kinetic energy are moving in circular orbits of radii r_e, r_p, r_α respectively in a uniform magnetic field B . The relation between r_e, r_p, r_α is:
- (1) $r_e < r_\alpha < r_p$ (2) $r_e > r_p = r_\alpha$
 (3) $r_e < r_p = r_\alpha$ (4) $r_e < r_p < r_\alpha$

Sol. (3)

$$r = \frac{\sqrt{2Km}}{qB} \quad (K \rightarrow \text{Kinetic energy})$$

$$r \propto \frac{\sqrt{m}}{q}$$

$$\text{So } r_e < r_p = r_\alpha$$

55. On interchanging the resistances, the balance point of a meter bridge shifts to the left by 10 cm. The resistance of their series combination is 1 k Ω . How much was the resistance on the left slot before interchanging the resistances?

- (1) 910 Ω (2) 990 Ω
(3) 505 Ω (4) 550 Ω

Sol. (4)

$$\frac{R_1}{R_2} = \frac{\ell}{100 - \ell} \quad \dots(i)$$

$$\text{and } \frac{R_2}{R_1} = \frac{\ell - 10}{100 - (\ell - 10)} \quad \dots(ii)$$

From (i) and (ii)

$$\Rightarrow \ell = 55 \text{ cm.}$$

$$\frac{R_1}{R_2} = \frac{55}{45} \quad \dots(i)$$

$$\text{and } R_1 + R_2 = 1000 \Omega \quad \dots(iii)$$

from (i) and (iii)

$$R_1 = 550 \Omega$$

56. In a potentiometer experiment, it is found that no current passes through the galvanometer when the terminals of the cell are connected across 52 cm of the potentiometer wire. If the cell is shunted by a resistance of 5 Ω , a balance is found when the cell is connected across 40 cm of the wire. Find the internal resistance of the cell.

- (1) 2.5 Ω (2) 1 Ω
(3) 1.5 Ω (4) 2 Ω

Sol. (3)

When the cell is shunted by a resistance of 5 Ω

$$i = \frac{\varepsilon}{5 + r}$$

$$\text{Now } \frac{\varepsilon - ir}{\varepsilon} = \frac{40}{52}$$

$$\frac{r}{5 + r} = \frac{3}{13}$$

$$\therefore r = 1.5 \Omega$$

57. If the series limit frequency of the Lyman series is ν_L , then the series limit frequency of the Pfund series is:

- (1) $\nu_L/25$ (2) $25 \nu_L$
(3) $16 \nu_L$ (4) $\nu_L/16$

Sol. (1)

Series limit frequency of the Lyman series is given by

$$\nu_L = RcZ \left(\frac{1}{1^2} - \frac{1}{\infty^2} \right)$$

$$\nu_L = RcZ \quad \dots(1)$$

Series limit frequency of the Pfund series $\nu_p = RcZ \left(\frac{1}{5^2} - \frac{1}{\infty^2} \right)$

$$\nu_p = \frac{\nu_L}{25}$$

58. The angular width of the central maximum in a single slit diffraction pattern is 60° . The width of the slit is $1 \mu\text{m}$. The slit is illuminated by monochromatic plane waves. If another slit of same width is made near it, Young's fringes can be observed on a screen placed at a distance 50 cm from the slits. If the observed fringe width is 1 cm, what is slit separation distance?

(i.e. distance between the centres of each slit.)

- (1) $100 \mu\text{m}$ (2) $25 \mu\text{m}$
(3) $50 \mu\text{m}$ (4) $75 \mu\text{m}$

Sol. (2)

$$\sin 30^\circ = \frac{\lambda}{b} \Rightarrow \lambda = \frac{b}{2} = \frac{1 \times 10^{-6}}{2} = 5 \times 10^{-7} \text{ m}$$

$$\text{Fringe width, } \omega = \frac{\lambda D}{d} \Rightarrow d = \frac{\lambda D}{\omega} = \frac{5 \times 10^{-7} \times 0.5}{1 \times 10^{-2}}$$

$$d = 25 \mu\text{m}$$

59. A particle is moving in a circular path of radius a under the action of an attractive potential $U = -\frac{k}{2r^2}$. Its

total energy is:

- (1) $\frac{3k}{2a}$ (2) $\frac{k}{4a^2}$
(3) $\frac{k}{2a^2}$ (4) Zero

Sol. (4)

$$\text{Given } U = -\frac{k}{2r^2} \Rightarrow F = -\frac{dU}{dr} = -\frac{k}{r^3}$$

Since the particle moves in a circular path of radius 'a'

$$\frac{mv^2}{a} = \frac{k}{a^3} \Rightarrow mv^2 = \frac{k}{a^2} \quad \dots(1)$$

$$\text{Kinetic Energy} = \frac{1}{2} mv^2 = \frac{k}{2a^2}$$

$$\text{Total Energy} = -\frac{k}{2a^2} + \frac{k}{2a^2} = 0$$

60. A silver atom in a solid oscillates in simple harmonic motion in some direction with a frequency of $10^{12}/\text{sec}$. What is the force constant of the bonds connecting one atom with the other? (Mole wt. of silver = 108 and Avogadro number = $6.02 \times 10^{23} \text{ gm mole}^{-1}$)

- (1) 5.5 N/m (2) 6.4 N/m
(3) 7.1 N/m (4) 2.2 N/m

Sol. (3)

Given frequency $f = 10^{12} / \text{sec}$.

Angular frequency $\omega = 2\pi f = 2\pi \times 10^{12} / \text{sec}$

Force constant $k = m\omega^2$

$$= \frac{108 \times 10^{-3}}{6.02 \times 10^{23}} \times 4\pi^2 \times 10^{24}$$

$$k = 7.1 \text{ N/m}$$

PART C - CHEMISTRY

61. For 1 molal aqueous solution of the following compounds, which one will show the highest freezing point?

- (1) $[\text{Co}(\text{H}_2\text{O})_3 \text{Cl}_3] \cdot 3\text{H}_2\text{O}$ (2) $[\text{Co}(\text{H}_2\text{O})_6] \text{Cl}_3$
 (3) $[\text{Co}(\text{H}_2\text{O})_5 \text{Cl}] \text{Cl}_2 \cdot \text{H}_2\text{O}$ (4) $[\text{Co}(\text{H}_2\text{O})_4 \text{Cl}_2] \text{Cl} \cdot 2\text{H}_2\text{O}$

Sol. (1)

The complex giving least number of ions will have lowest depression in freezing point and therefore highest freezing point. Hence, option 1 is correct. (Van't Hoff factor = 1)

62. Hydrogen peroxide oxidises $[\text{Fe}(\text{CN})_6]^{4-}$ to $[\text{Fe}(\text{CN})_6]^{3-}$ in acidic medium but reduces $[\text{Fe}(\text{CN})_6]^{3-}$ to $[\text{Fe}(\text{CN})_6]^{4-}$ in alkaline medium. The other products formed are, respectively

- (1) H_2O and $(\text{H}_2\text{O} + \text{OH}^-)$ (2) $(\text{H}_2\text{O} + \text{O}_2)$ and H_2O
 (3) $(\text{H}_2\text{O} + \text{O}_2)$ and $(\text{H}_2\text{O} + \text{OH}^-)$ (4) H_2O and $(\text{H}_2\text{O} + \text{O}_2)$

Sol. (4)

In acidic medium

Oxidation number decreases

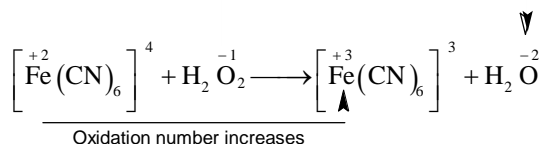

In alkaline medium

Oxidation number increases

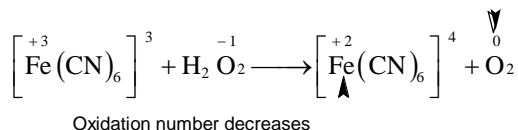

63. Which of the following compounds will be suitable for Kjeldahl's method for nitrogen estimation?

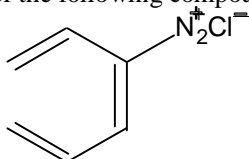
(1) 

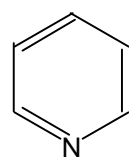
(2) 

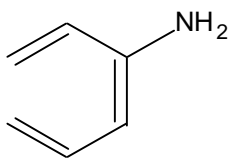
(3) 

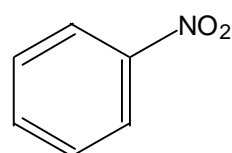
(4) 

Sol. (3)
Kjeldahl's method is not used in the case of nitro, azo compounds and also to the compounds containing nitrogen in the ring e.g. Pyridine.

64. Glucose on prolonged heating with HI gives
 (1) 6-iodohexanal (2) n-Hexane
 (3) 1-Hexene (4) Hexanoic acid

Sol. (2)

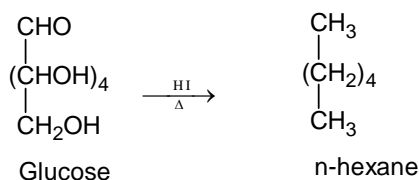

65. An alkali is titrated against an acid with methyl orange as indicator, which of the following is a correct combination?

| | Base | Acid | End point |
|-----|-------------|-------------|-----------------------|
| (1) | Strong | Strong | Pink to colourless |
| (2) | Weak | Strong | Colourless to pink |
| (3) | Strong | Strong | Pinkish red to yellow |
| (4) | Weak | Strong | Yellow to pinkish red |

Sol. (4)

Methyl orange is weak organic base. It is used in the titration of WB vs SA

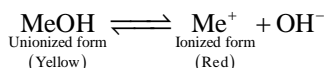

In basic medium, equilibrium lies in backward direction and therefore it shows yellow colour.

In acidic medium, equilibrium shifts in forward direction and therefore, colour changes from yellow to red.

66. The predominant form of histamine present in human blood is (pK_a , Histidine = 6.0)

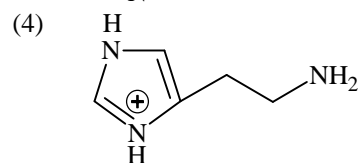
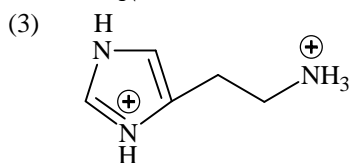
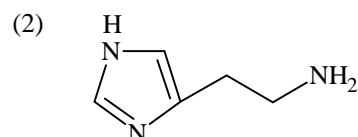
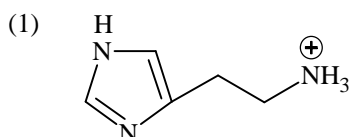

Sol. (1)

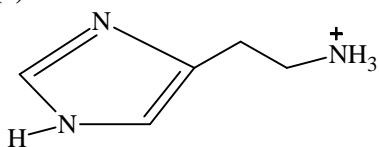

The N-atoms present in the ring will have same pK_a values (6.0), while N atom outside the ring will have different pK_a value ($pK_a > 7.4$)

Therefore, two N-atoms inside the ring will remain in unprotonated form in human blood because their $pK_a(6.0) < \text{pH of blood (7.4)}$, while the N-atom outside the ring will remain in protonated form because its $pK_a > \text{pH of blood (7.4)}$.

67. The increasing order of basicity of the following compounds is:

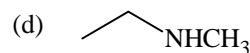
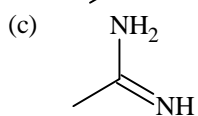
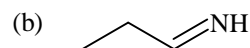
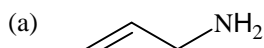

(1) (d) < (b) < (a) < (c)

(2) (a) < (b) < (c) < (d)

(3) (b) < (a) < (c) < (d)

(4) (b) < (a) < (d) < (c)

Sol.

(4)

Order of basicity is

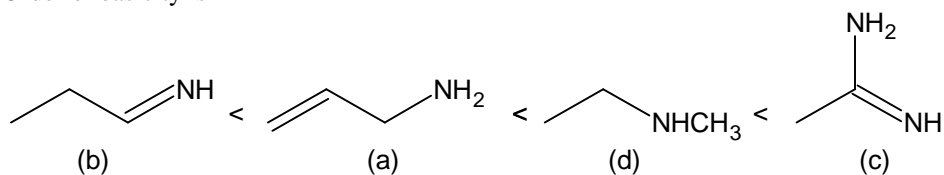

c is most basic because its conjugate acid is stabilized by equivalent resonance.

Out of a and d, d is more basic due to +I effect. b is less basic than a and d because N atom is sp^2 hybridized.

68. Which of the following lines correctly show the temperature dependence of equilibrium constant K, for an exothermic reaction?

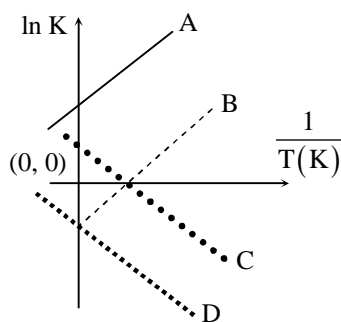

(1) A and D

(2) A and B

(3) B and C

(4) C and D

Sol.

(2)

$$\Delta G^0 = -RT \ln K$$

$$\Delta H^0 - T\Delta S^0 = -RT \ln K$$

$$-\frac{\Delta H^0}{RT} + \frac{\Delta S^0}{R} = \ln K$$

Therefore $\ln K$ vs $\frac{1}{T}$ graph will be a straight line with slope equal to $-\frac{\Delta H^0}{R}$. Since reaction is exothermic, therefore ΔH^0 itself will be negative resulting in positive slope.

69. How long (approximate) should water be electrolysed by passing through 100 amperes current so that the oxygen released can completely burn 27.66 g of diborane?

(Atomic weight of B = 10.8 u)

(1) 1.6 hours

(2) 6.4 hours

(3) 0.8 hours

(4) 3.2 hours

Sol. (4)

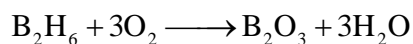

According to balanced equation:

27.66 g B_2H_6 i.e. 1 mole B_2H_6 requires 3 mole of O_2 . Now this oxygen is produced by electrolysis of water.

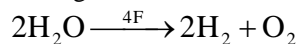

1 mole O_2 is produced by 4 F charge

\therefore 3 mole O_2 will be produced by 12 F charge

\therefore Now applying

$$Q = It$$

$$12 \times 96500 \text{ C} = 100 \times t \text{ (s)}$$

$$t = \frac{12 \times 96500}{100 \times 3600} \text{ hours}$$

$$t = 3.2 \text{ hours}$$

70. Consider the following reaction and statements:

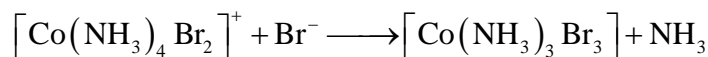

(I) Two isomers are produced if the reactant complex ion is a cis-isomer

(II) Two isomers are produced if the reactant complex ion is a trans-isomer

(III) Only one isomer is produced if the reactant complex ion is a trans-isomer

(IV) Only one isomer is produced if the reactant complex ion is a cis – isomer

The correct statements are

(1) (II) and (IV)

(2) (I) and (II)

(3) (I) and (III)

(4) (III) and (IV)

Sol. (3)

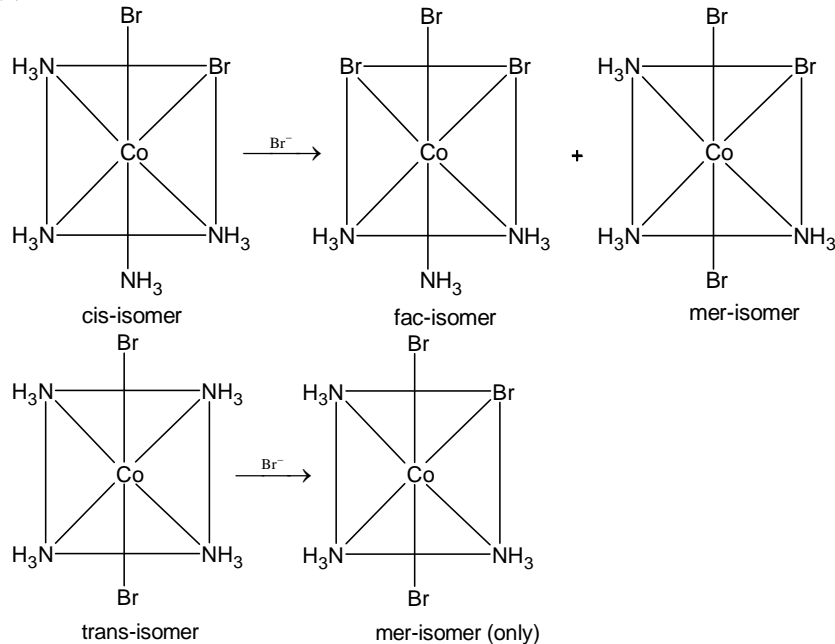

$$\Delta H = \left(-3263900 - \frac{3}{2} \times 8.314 \times 298 \right) \text{J}$$

$$= -3267616 \text{ J}$$

$$= -3267.616 \text{ kJ}$$

75. The ratio of mass percent of C and H of an organic compound ($C_xH_yO_z$) is 6 : 1. If one molecule of the above compound ($C_xH_yO_z$) contains half as much oxygen as required to burn one molecule of compound C_xH_y completely to CO_2 and H_2O . The empirical formula of compound $C_xH_yO_z$ is
- (1) $C_2H_4O_3$ (2) $C_3H_6O_3$
 (3) C_2H_4O (4) $C_3H_4O_2$

Sol.

(1)

Ratio of mass % of C and H in $C_xH_yO_z$ is 6 : 1.

Therefore,

Ratio of mole % of C and H in $C_xH_yO_z$ will be 1 : 2.

Therefore $x : y = 1 : 2$, which is possible in options 1, 2 and 3.

Now oxygen required to burn C_xH_y

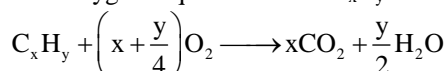

Now z is half of oxygen atoms required to burn C_xH_y .

$$\therefore z = \frac{\left(2x + \frac{y}{2} \right)}{2} = \left(x + \frac{y}{4} \right)$$

Now putting values of x and y from the given options:

Option (1), $x = 2$, $y = 4$

$$z = \left(2 + \frac{4}{4} \right) = 3$$

Option 2, $x = 3$, $y = 6$

$$z = \left(3 + \frac{6}{4} \right) = 4.5$$

Therefore correct option is 1 ($C_2H_4O_3$)

76. The trans-alkenes are formed by the reduction of alkynes with
- (1) Sn - HCl (2) $H_2 - Pd/C, BaSO_4$
 (3) $NaBH_4$ (4) Na/liq. NH_3

Sol.

(4)

Na/Liq. NH_3 reduces alkynes into *trans* alkene (*trans* addition).

77. Which of the following are Lewis acids?
- (1) BCl_3 and $AlCl_3$ (2) PH_3 and BCl_3
 (3) $AlCl_3$ and $SiCl_4$ (4) PH_3 and $SiCl_4$

Sol.

(1 or 3)

Both BCl_3 and $AlCl_3$ are Lewis acids as both 'B' and 'Al' has vacant p-orbitals. $SiCl_4$ is also a Lewis acid as silicon atom has vacant 3d-orbital.

78. When metal 'M' is treated with NaOH, a white gelatinous precipitate 'X' is obtained, which is soluble in excess of NaOH. Compound 'X' when heated strongly gives an oxide which is used in chromatography as an adsorbent. The metal 'M' is
- (1) Fe (2) Zn
 (3) Ca (4) Al

Sol. (4)

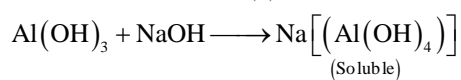
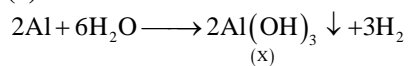

79. According to molecular orbital theory, which of the following will not be a viable molecule?

- (1) H_2^{2-} (2) He_2^{2+}
(3) He_2^+ (4) H_2^-

Sol. (1)

| Species | Bond order |
|------------------------|---|
| (1) H_2^{2-} | B. O. = $\frac{1}{2}[2-2] = 0$ (does not exist) |
| (2) He_2^{2+} | B. O. = $\frac{1}{2}[2-0] = 1$ (exists) |
| (3) He_2^+ | B. O. = $\frac{1}{2}[2-1] = 0.5$ (exists) |
| (4) H_2^- | B. O. = $\frac{1}{2}[2-1] = 0.5$ (exists) |

80. The major product formed in the following reaction is:

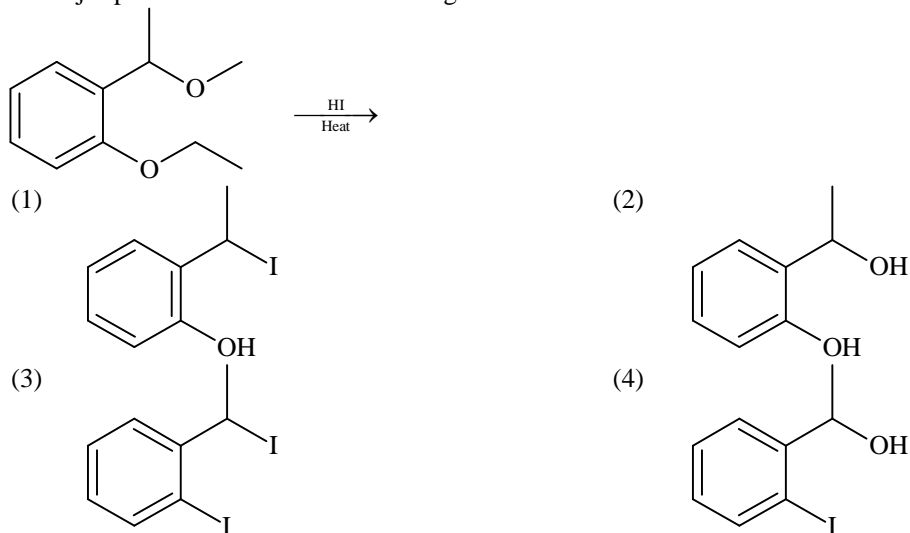

Sol. (1)

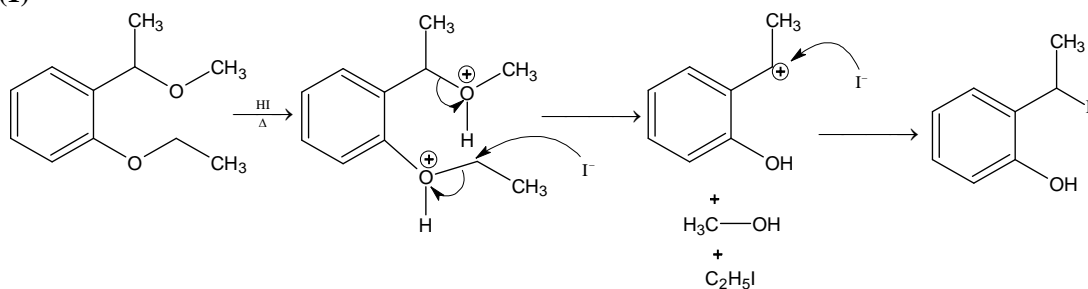

81. Phenol on treatment with CO_2 in the presence of NaOH followed by acidification produces compound X as the major product. X on treatment with $(\text{CH}_3\text{CO})_2\text{O}$ in the presence of catalytic amount of H_2SO_4 produces:

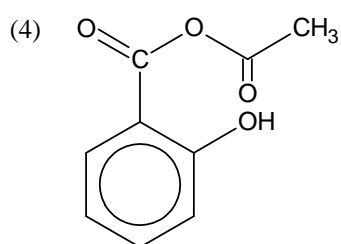
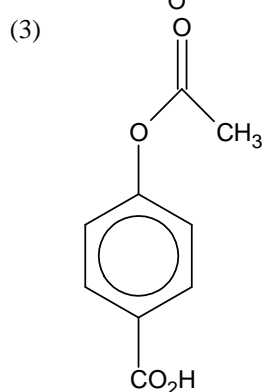
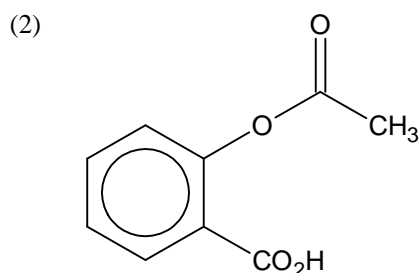
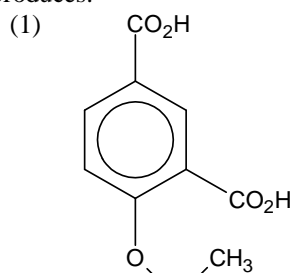

Sol. (2)

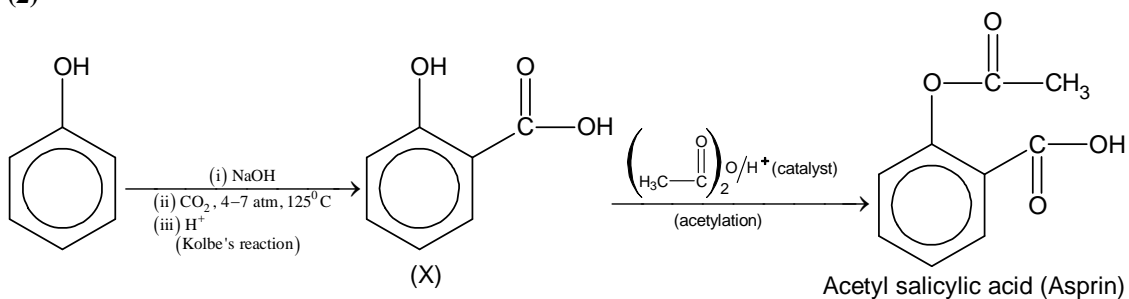

82. Which of the following compounds contain(s) no covalent bond(s)?

KCl , PH_3 , O_2 , B_2H_6 , H_2SO_4

- (1) KCl , B_2H_6
 (3) KCl , H_2SO_4

- (2) KCl , B_2H_6 , PH_3
 (4) KCl

Sol. (4)

KCl contains only ionic bond between K^+ and Cl^- ions (K^+Cl^-) while other structures have covalent bonds as follows:

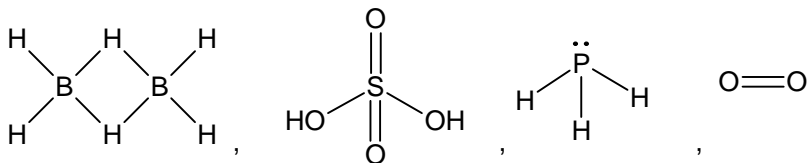

83. Which type of 'defect' has the presence of cations in the interstitial sites?
 (1) Metal deficiency defect (2) Schottky defect
 (3) Vacancy defect (4) Frenkel defect

Sol. (4)
 In Frenkel defect, smaller ion displaces from its actual lattice site into the interstitial sites.

84. The major product of the following reaction is:

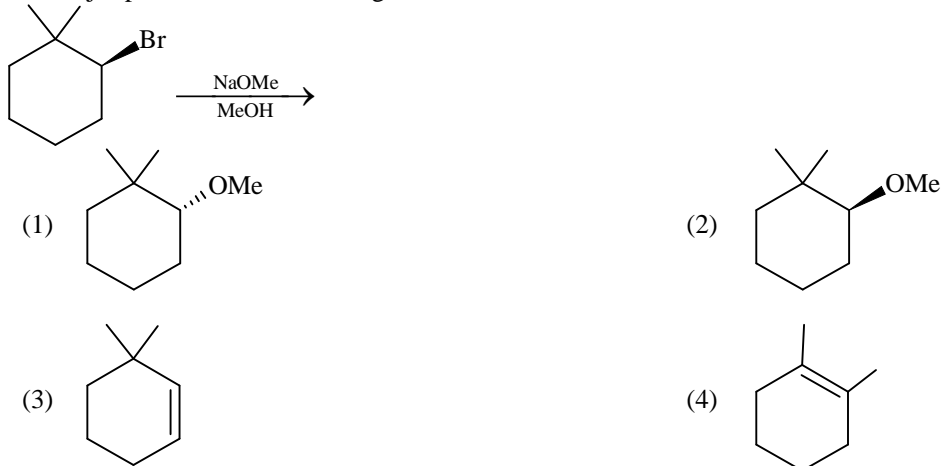

Sol. (3)
 It follows E2 mechanism.

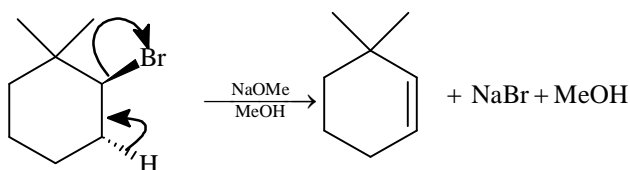

85. The compound that does not produce nitrogen gas by the thermal decomposition is
 (1) $(\text{NH}_4)_2\text{SO}_4$ (2) $\text{Ba}(\text{N}_3)_2$
 (3) $(\text{NH}_4)_2\text{Cr}_2\text{O}_7$ (4) NH_4NO_2

Sol. (1)

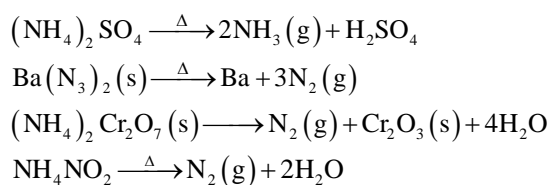

86. An aqueous solution contains 0.10 M H_2S and 0.20 M HCl. If the equilibrium constants for the formation of HS^- from H_2S is 1.0×10^{-7} and that of S^{2-} from HS^- ions is 1.2×10^{-13} then the concentration of S^{2-} ions in aqueous solution is
 (1) 5×10^{-19} (2) 5×10^{-8}
 (3) 3×10^{-20} (4) 6×10^{-21}

