

Solutions to JEE (Main) -2016

PARTA – CHEMISTRY

1. A stream of electrons from a heated filament was passed between two charged plates kept at a potential difference V esu. If e and m are charge and mass of an electron, respectively, then the value of h/λ (where λ is wavelength associated with electron wave) is given by :

- (1) $2meV$ (2) \sqrt{meV}
(3) $\sqrt{2meV}$ (4) meV

Sol. (3)

$$\lambda = \frac{h}{mv}$$
$$= \frac{h}{\sqrt{2m(\text{KE})}}$$
$$\therefore \frac{h}{\lambda} = \sqrt{2meV}$$

2. 2-chloro-2-methylpentane on reaction with sodium methoxide in methanol yields :

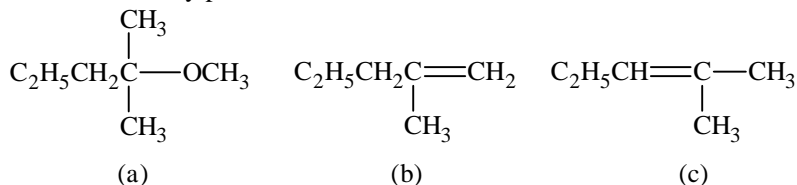

- (1) (a) and (c) (2) (c) only
(3) (a) and (b) (4) All of these

Sol. (4)

via S_N1 and E_2 mechanisms

3. Which of the following compounds is metallic and ferromagnetic ?

- (1) CrO_2 (2) VO_2
(3) MnO_2 (4) TiO_2

Sol. (1)

CrO_2 is metallic and ferromagnetic.

4. Which of the following statements about low density polythene is FALSE ?

- (1) It is a poor conductor of electricity.
(2) Its synthesis requires dioxygen or a peroxide initiator as a catalyst.
(3) It is used in the manufacture of buckets, dust-bins etc.
(4) Its synthesis requires high pressure.

Sol. (3)

HDPE is used in making buckets and dustbins

5. For a linear plot of $\log(x/m)$ versus $\log p$ in a Freundlich adsorption isotherm, which of the following statements is correct ? (k and n are constants)

- (1) $1/n$ appears as the intercept. (2) Only $1/n$ appears as the slope
(3) $\log(1/n)$ appears as the intercept. (4) Both k and $1/n$ appear in the slope term.

Sol. (2)

$$\frac{x}{m} = kp^{\frac{1}{n}}$$

$$\log \frac{x}{m} = \log k + \frac{1}{n} \log p$$

6. The heats of combustion of carbon and carbon monoxide are -393.5 and $-283.5 \text{ kJ mol}^{-1}$, respectively. The heat of formation (in kJ) of carbon monoxide per mole is :

- (1) 676.5 (2) -676.5
(3) -110.5 (4) 110.5

Sol. (3)

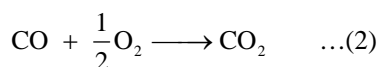
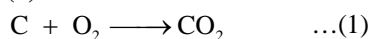

$$\Delta H_1 \Rightarrow -393.5 \text{ kJ / mole}$$

$$\Delta H_2 \Rightarrow -283.5 \text{ kJ / mole}$$

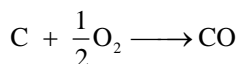

$$\Delta_f H_{(\text{CO}, \text{g})} = \Delta H_1 - \Delta H_2$$

$$\Rightarrow -393.5 - (-283.5)$$

$$= -393.5 + 283.5$$

$$\Rightarrow -110 \text{ kJ/mole}$$

7. The hottest region of Bunsen flame shown in the figure below is :

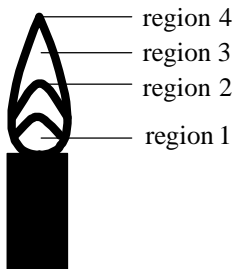

- (1) region 2 (2) region 3
(3) region 4 (4) region 1

Sol. (1)
region 2

8. Which of the following is an anionic detergent ?

- (1) Sodium lauryl sulphate (2) Cetyltrimethyl ammonium bromide
(3) Glyceryl oleate (4) Sodium stearate

Sol. (1)
Sodium $^+(\text{lauryl sulphate})^-$ is an anionic detergent.

9. 18 g glucose ($\text{C}_6\text{H}_{12}\text{O}_6$) is added to 178.2 g water. The vapour pressure of water (in torr) for this aqueous solution is :

- (1) 76.0 (2) 752.4
(3) 759.0 (4) 7.6

Sol. (2)

$$n_{\text{C}_6\text{H}_{12}\text{O}_6} = 0.1$$

$$n_{\text{H}_2\text{O}} = \frac{178.2}{18} = 9.9$$

$$\frac{p^0 - p}{p^0} \Rightarrow \frac{0.1}{10}$$

$$p^0 - p \Rightarrow \frac{0.1}{10} \times 760 = 7.6$$

$$p = p^0 - 7.6$$

$$= 760 - 7.6$$

$$= 752.4 \text{ torr}$$

10. The distillation technique most suited for separating glycerol from spent-lye in the soap industry is :

- (1) Fractional distillation (2) Steam distillation
(3) Distillation under reduced pressure (4) Simple distillation

Sol. (3)

Glycerol decomposes before its boiling point.

11. The species in which the N atom is in a state of *sp* hybridization is :

- (1) NO_2^- (2) NO_3^-
(3) NO_2 (4) NO_2^+

Sol. (4)

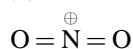

12. Decomposition of H_2O_2 follows a first order reaction. In fifty minutes the concentration of H_2O_2 decreases from 0.5 to 0.125 M in one such decomposition. When the concentration of H_2O_2 reaches 0.05 M, the rate of formation of O_2 will be :

- (1) $6.93 \times 10^{-4} \text{ mol min}^{-1}$ (2) 2.66 L min^{-1} at STP
(3) $1.34 \times 10^{-2} \text{ mol min}^{-1}$ (4) $6.93 \times 10^{-2} \text{ mol min}^{-1}$

Sol. (1)

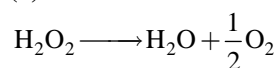

$$2t_{1/2} = 50 \text{ mins}$$

$$t_{1/2} = 25 \text{ mins}$$

$$\therefore k = \frac{0.693}{25}$$

$$-\frac{d[\text{H}_2\text{O}_2]}{dt} = \frac{d[\text{O}_2]}{dt} \times 2$$

$$\therefore \frac{d[\text{O}_2]}{dt} = \frac{1}{2} \times \frac{0.693}{25} \times 0.05$$

$$= 6.93 \times 10^{-4}$$

13. The pair having the same magnetic moment is :

[At. No.: Cr = 24, Mn = 25, Fe = 26, Co = 27]

- (1) $[\text{Cr}(\text{H}_2\text{O})_6]^{2+}$ and $[\text{Fe}(\text{H}_2\text{O})_6]^{2+}$ (2) $[\text{Mn}(\text{H}_2\text{O})_6]^{2+}$ and $[\text{Cr}(\text{H}_2\text{O})_6]^{2+}$
(3) $[\text{CoCl}_4]^{2-}$ and $[\text{Fe}(\text{H}_2\text{O})_6]^{2+}$ (4) $[\text{Cr}(\text{H}_2\text{O})_6]^{2+}$ and $[\text{CoCl}_4]^{2-}$

Sol. (1)

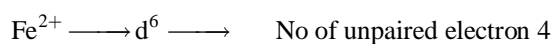
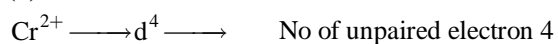

Both configurations have 4 unpaired electrons due to weak field ligands.

14. The absolute configuration of

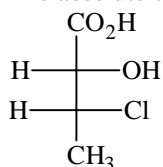

(1) (2S, 3R)

(2) (2S, 3S)

(3) (2R, 3R)

(4) (2R, 3S)

Sol. (1)

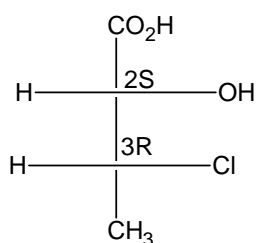

15. The equilibrium constant at 298 K for a reaction $\text{A} + \text{B} \rightleftharpoons \text{C} + \text{D}$ is 100. If the initial concentration of all the four species were 1M each, then equilibrium concentration of D (in mol L^{-1}) will be:

(1) 0.818

(2) 1.818

(3) 1.182

(4) 0.182

Sol. (2)

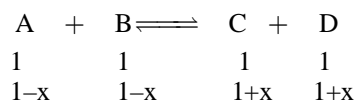

Given $K_{\text{eq}} = 100$

$$\frac{(1+x)^2}{(1-x)^2} = 100$$

$$\frac{1+x}{1-x} = 10$$

$$1+x = 10 - 10x$$

$$11x = 9$$

$$x = \frac{9}{11}$$

$$[\text{D}] = 1 + \frac{9}{11}$$

$$= 1 + 0.818$$

$$= 1.818$$

16. Which one of the following ores is best concentrated by froth floatation method?
 (1) Siderite (2) Galena
 (3) Malachite (4) Magnetite

Sol. (2)
 Galena (PbS) is a sulphide ore.

17. At 300 K and 1 atm, 15 mL of a gaseous hydrocarbon requires 375 mL air containing 20% O₂ by volume for complete combustion. After combustion the gases occupy 330 mL. Assuming that the water formed is in liquid form and the volumes were measured at the same temperature and pressure, the formula of the hydrocarbon is:

- (1) C₃H₈ (2) C₄H₈
 (3) C₄H₁₀ (4) C₃H₆

Sol. None

$$\text{Volume of O}_2 = 375 \times \frac{20}{100} = 75 \text{ ml}$$

$$\text{Volume of gaseous hydrocarbon} = 15 \text{ ml}$$

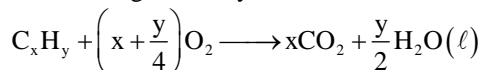

$$15\left(x + \frac{y}{4}\right) = 75 \quad \dots(1)$$

$$x + \frac{y}{4} = 5$$

$$\text{Excess air} = 375 - 75 = 300$$

$$300 + \text{volume of CO}_2 = 330$$

$$\text{Volume of CO}_2 = 30$$

$$15x = 30$$

$$x = 2$$

(Correct option is not given)

$$2 + \frac{y}{4} = 5$$

$$\frac{y}{4} = 3$$

$$y = 12$$

$$\text{C}_2\text{H}_{12} \text{ (not possible)}$$

Hence No answer is correct.

However, considering the equation no. 1 alone, if we put x and y values, 3 and 8 respectively, then equation no. 1 is satisfied and answer will be C₃H₈.

18. The pair in which phosphorous atoms have a formal oxidation state of +3 is:

- (1) Pyrophosphorous and hypophosphoric acids
 (2) Orthophosphorous and hypophosphoric acids
 (3) Pyrophosphorous and pyrophosphoric acids
 (4) Orthophosphorous and pyrophosphorous acids

Sol. (4)

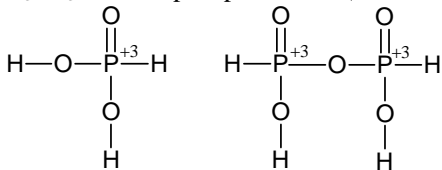
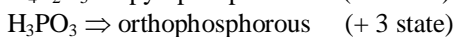

19. Which one of the following complexes shows optical isomerism?
 (1) $cis[Co(en)_2Cl_2]Cl$ (2) $trans[Co(en)_2Cl_2]Cl$
 (3) $[Co(NH_3)_4Cl_2]Cl$ (4) $[Co(NH_3)_3Cl_3]$
 (en = ethylenediamine)

Sol.

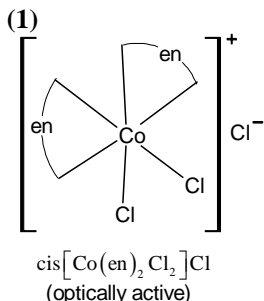

20. The reaction of zinc with dilute and concentrated nitric acid, respectively, produces:
 (1) NO_2 and NO (2) NO and N_2O
 (3) NO_2 and N_2O (4) N_2O and NO_2

Sol. (4)

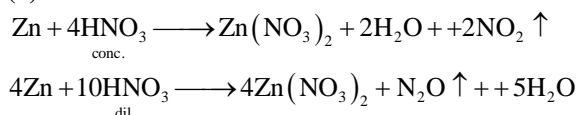

21. Which one of the following statements about water is **FALSE**?
 (1) Water can act both as an acid and as a base.
 (2) There is extensive intramolecular hydrogen bonding in the condensed phase.
 (3) Ice formed by heavy water sinks in normal water
 (4) Water is oxidized to oxygen during photosynthesis

Sol. (2)

Ice shows intermolecular H – bonding.

22. The concentration of fluoride, lead, nitrate and iron in a water sample from an underground lake was found to be 1000 ppb, 40 ppb, 100 ppm and 0.2 ppm, respectively. This water is unsuitable for drinking due to high concentration of :
 (1) Lead (2) Nitrate
 (3) Iron (4) Fluoride

Sol. (2)

Maximum limit of nitrate in potable water is 50 ppm.

23. The main oxides formed on combustion of Li, Na and K in excess of air are, respectively:
 (1) LiO_2 , Na_2O_2 and K_2O (2) Li_2O_2 , Na_2O_2 and KO_2
 (3) Li_2O , Na_2O_2 and KO_2 (4) Li_2O , Na_2O and KO_2

Sol. (3)

24. Thiol group is present in :
 (1) Cystine (2) Cysteine
 (3) Methionine (4) Cytosine

Sol. (2)

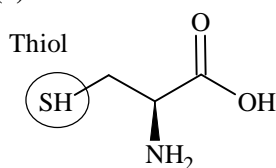

25. Galvanization is applying a coating of:

- (1) Cr (2) Cu
(3) Zn (4) Pb

Sol. (3)

26. Which of the following atoms has the highest first ionization energy?

- (1) Na (2) K
(3) Sc (4) Rb

Sol. (3)

27. In the Hofmann bromamide degradation reaction, the number of moles of NaOH and Br₂ used per mole of amine produced are:

- (1) Four moles of NaOH and two moles of Br₂.
(2) Two moles of NaOH and two moles of Br₂
(3) Four moles of NaOH and one mole of Br₂
(4) One mole of NaOH and one mole of Br₂

Sol. (3)

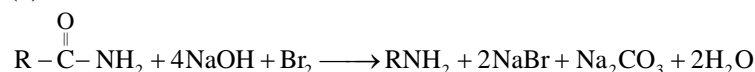

28. Two closed bulbs of equal volume (V) containing an ideal gas initially at pressure p_i and temperature T_1 are connected through a narrow tube of negligible volume as shown in the figure below. The temperature of one of the bulbs is then raised to T_2 . The final pressure p_f is

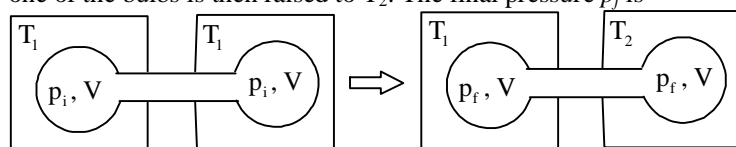

- (1) $2p_i \left(\frac{T_1}{T_1 + T_2} \right)$ (2) $2p_i \left(\frac{T_2}{T_1 + T_2} \right)$
(3) $2p_i \left(\frac{T_1 T_2}{T_1 + T_2} \right)$ (4) $p_i \left(\frac{T_1 T_2}{T_1 + T_2} \right)$

Sol. (2)

Initial total moles:

$$n = \frac{p_i V}{RT_1} + \frac{p_i V}{RT_1} = \frac{2p_i V}{RT_1} \quad \dots (1)$$

Final total moles:

$$n = \frac{p_f V}{RT_1} + \frac{p_f V}{RT_2} \quad \dots (2)$$

Equating the two:

$$\frac{2p_i}{T_1} = \frac{p_f}{T_1} + \frac{p_f}{T_2}$$

$$p_f = \frac{2p_i}{T_1} \times \frac{T_1 T_2}{(T_1 + T_2)}$$

$$p_f = 2p_i \times \frac{T_2}{T_1 + T_2}$$

29. The reaction of propene with HOCl ($\text{Cl}_2 + \text{H}_2\text{O}$) proceeds through the intermediate:
- (1) $\text{CH}_3 - \text{CH}^+ - \text{CH}_2 - \text{Cl}$ (2) $\text{CH}_3 - \text{CH}(\text{OH}) - \text{CH}_2^+$
 (3) $\text{CH}_3 - \text{CHCl} - \text{CH}_2^+$ (4) $\text{CH}_3 - \text{CH}^+ - \text{CH}_2 - \text{OH}$

Sol. (1)



30. The product of the reaction given below is:

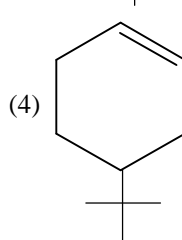
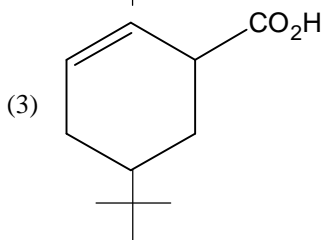
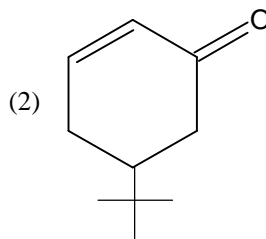
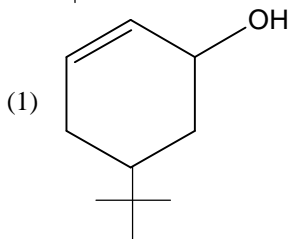
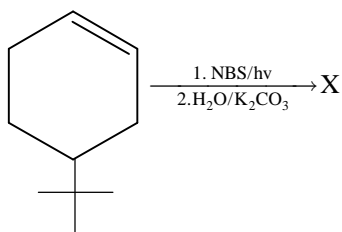

Sol. (1)
Allylic bromination followed by hydrolysis.

PART B – MATHEMATICS

31. Two sides of a rhombus are along the lines, $x - y + 1 = 0$ and $7x - y - 5 = 0$. If its diagonals intersect at $(-1, -2)$, then which one of the following is a vertex of this rhombus?

- (1) $(-3, -8)$ (2) $\left(\frac{1}{3}, -\frac{8}{3}\right)$
 (3) $\left(-\frac{10}{3}, -\frac{7}{3}\right)$ (4) $(-3, -9)$

Sol. (2)

Remaining two sides of rhombus are $x - y - 3 = 0$ and $7x - y + 15 = 0$.

So on solving, we get vertices as $\left(\frac{1}{3}, -\frac{8}{3}\right)$, $(1, 2)$, $\left(-\frac{7}{3}, -\frac{4}{3}\right)$ and $(-3, -6)$.

32. If the 2nd, 5th and 9th terms of a non-constant A.P. are in G.P., then the common ratio of this G.P. is:

- (1) $\frac{4}{3}$ (2) 1
 (3) $\frac{7}{4}$ (4) $\frac{8}{5}$

Sol. (1)

Let the G.P. be a, ar, ar^2 and terms of A.P. are $A + d, A + 4d, A + 8d$

$$\text{then } \frac{ar^2 - ar}{ar - a} = \frac{(A + 8d) - (A + 4d)}{(A + 4d) - (A + d)} = \frac{4}{3}$$

$$\Rightarrow r = \frac{4}{3}.$$

Alternate Solution:

Let AP is $a, a + d, a + 2d \dots$

2nd, 5th and 9th terms $a + d, a + 4d, a + 8d$ are in GP

$$\Rightarrow (a + 4d)^2 = (a + d)(a + 8d)$$

$$\Rightarrow d(8d - a) = 0 \Rightarrow 8d = a \text{ as } d \neq 0$$

$$\text{Hence common ratio of GP } \frac{a + 4d}{a + d} = \frac{8d + 4d}{8d + d} = \frac{12d}{9d} = \frac{4}{3}.$$

33. Let P be the point on the parabola, $y^2 = 8x$ which is at a minimum distance from the centre C of the circle, $x^2 + (y + 6)^2 = 1$. Then the equation of the circle, passing through C and having its centre at P is:

- (1) $x^2 + y^2 - x + 4y - 12 = 0$ (2) $x^2 + y^2 - \frac{x}{4} + 2y - 24 = 0$
 (3) $x^2 + y^2 - 4x + 9y + 18 = 0$ (4) $x^2 + y^2 - 4x + 8y + 12 = 0$

Sol. (4)

Equation of normal at P is

$$y = -tx + 4t + 2t^3$$

It passes through C(0, -6)

$$\therefore -6 = 4t + 2t^3$$

$$\Rightarrow t^3 + 2t + 3 = 0$$

$$\Rightarrow t = -1$$

Hence P is (2, -4)

$$r = \sqrt{4+4} = 2\sqrt{2}$$

Equation of required circle

$$(x-2)^2 + (y+4)^2 = 8$$

$$\Rightarrow x^2 + y^2 - 4x + 8y + 12 = 0$$

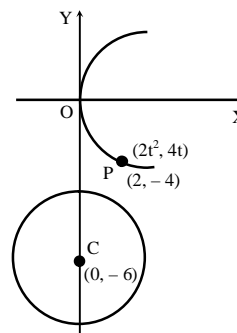

34. The system of linear equations

$$x + \lambda y - z = 0$$

$$\lambda x - y - z = 0$$

$$x + y - \lambda z = 0$$

has a non-trivial solution for :

(1) exactly one value of λ .

(2) exactly two values of λ .

(3) exactly three values of λ .

(4) infinitely many values of λ .

Sol. (3)

For non-trivial solution

$$\begin{vmatrix} 1 & \lambda & -1 \\ \lambda & -1 & -1 \\ 1 & 1 & -\lambda \end{vmatrix} = 0$$

$$1(\lambda + 1) - \lambda(-\lambda^2 + 1) - 1(\lambda + 1) = 0$$

$$\lambda + 1 + \lambda^3 - \lambda - \lambda - 1 = 0$$

$$\lambda(\lambda^2 - 1) = 0 \Rightarrow \lambda = 0, \lambda = \pm 1.$$

35. If $f(x) + 2f\left(\frac{1}{x}\right) = 3x$, $x \neq 0$, and $S = \{x \in \mathbb{R} : f(x) = f(-x)\}$; then S:

(1) contains exactly one element.

(2) contains exactly two elements.

(3) contains more than two elements.

(4) is an empty set.

Sol. (2)

$$f(x) + 2f\left(\frac{1}{x}\right) = 3x$$

replace x by $\frac{1}{x}$

$$f\left(\frac{1}{x}\right) + 2f(x) = \frac{3}{x}$$

$$\Rightarrow f(x) = \frac{2}{x} - x \text{ as } f(x) = f(-x) \Rightarrow x = \pm \sqrt{2}$$

36. Let $p = \lim_{x \rightarrow 0^+} (1 + \tan^2 \sqrt{x})^{\frac{1}{2x}}$ then log p is equal to:

(1) 1

(2) $\frac{1}{2}$

(3) $\frac{1}{4}$

(4) 2.

Sol. (2)

$$\begin{aligned}
 p &= \lim_{x \rightarrow 0^+} (1 + \tan^2 \sqrt{x})^{\frac{1}{2x}} \\
 &= e^{\lim_{x \rightarrow 0^+} \frac{\tan^2 \sqrt{x}}{2x}} \\
 &= e^{\lim_{x \rightarrow 0^+} \frac{1}{2} \left(\frac{\tan \sqrt{x}}{\sqrt{x}} \right)^2} \\
 p &= e^{\frac{1}{2}}
 \end{aligned}$$

37. A value of θ for which $\frac{2+3i \sin \theta}{1-2i \sin \theta}$ is purely imaginary, is:

- (1) $\frac{\pi}{6}$ (2) $\sin^{-1}\left(\frac{\sqrt{3}}{4}\right)$
 (3) $\sin^{-1}\left(\frac{1}{\sqrt{3}}\right)$ (4) $\frac{\pi}{3}$

Sol. (3)

$$\begin{aligned}
 \frac{2+3i \sin \theta}{1-2i \sin \theta} \text{ is purely imaginary} &\in \text{Arg}\left(\frac{2+3i \sin \theta}{1-2i \sin \theta}\right) = \frac{\pi}{2}, -\frac{\pi}{2} \\
 \Rightarrow \text{product of slopes taken as in } xy \text{ plane is } &-1 \\
 \Rightarrow \frac{3 \sin \theta}{2} \cdot \frac{-2 \sin \theta}{1} &= -1 \\
 \Rightarrow \sin^2 \theta = \frac{1}{3}, \theta = \sin^{-1}\left(\frac{1}{\sqrt{3}}\right).
 \end{aligned}$$

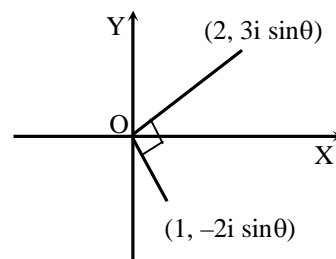

Alternate Solution:

$$\begin{aligned}
 \frac{2+3i \sin \theta}{1-2i \sin \theta} &= \frac{2-6 \sin^2 \theta + 7i \sin \theta}{1+4 \sin^2 \theta} \text{ is purely imaginary} \\
 \Rightarrow \frac{2-6 \sin^2 \theta}{1+4 \sin^2 \theta} &= 0 \Rightarrow 6 \sin^2 \theta = 2.
 \end{aligned}$$

38. The eccentricity of the hyperbola whose length of the latus rectum is equal to 8 and the length of its conjugate axis is equal half of the distance between its foci, is:

- (1) $\frac{4}{\sqrt{3}}$ (2) $\frac{2}{\sqrt{3}}$
 (3) $\sqrt{3}$ (4) $\frac{4}{3}$

Sol. (2)

$$\begin{aligned}
 \text{Given, } \frac{2b^2}{a} &= 8 \text{ and } 2b = \frac{1}{2}(2ae) \\
 2b &= ae \\
 4b^2 &= a^2 \cdot e^2 \\
 3e^2 = 4 &\Rightarrow e = \frac{2}{\sqrt{3}}
 \end{aligned}$$

39. If the standard deviation of the numbers 2, 3, a and 11 is 3.5, then which of the following is true?
- (1) $3a^2 - 32a + 84 = 0$ (2) $3a^2 - 34a + 91 = 0$
 (3) $3a^2 - 23a + 44 = 0$ (4) $3a^2 - 26a + 55 = 0$

Sol. (1)

$$\bar{x} = \frac{2+3+a+11}{4} = \frac{a}{4} + 4$$

$$\sigma = \sqrt{\sum \frac{x_i^2}{n} - (\bar{x})^2}$$

$$3.5 = \sqrt{\frac{4+9+a^2+121}{4} - \left(\frac{a}{4} + 4\right)^2}$$

$$\Rightarrow \frac{49}{4} = \frac{4(134+a^2) - (a^2 + 256 + 32a)}{16}$$

$$\Rightarrow 3a^2 - 32a + 84 = 0$$

40. The integral $\int \frac{2x^{12} + 5x^9}{(x^5 + x^3 + 1)^3} dx$ is equal to:

- (1) $\frac{x^{10}}{2(x^5 + x^3 + 1)^2} + C$ (2) $\frac{x^5}{2(x^5 + x^3 + 1)^2} + C$
 (3) $\frac{-x^{10}}{2(x^5 + x^3 + 1)^2} + C$ (4) $\frac{-x^5}{(x^5 + x^3 + 1)^2} + C$

where C is an arbitrary constant.

Sol. (1)

$$I = \int \frac{\left(\frac{2}{x^3} + \frac{5}{x^6}\right)}{\left(1 + \frac{1}{x^2} + \frac{1}{x^5}\right)^3} dx, \quad \text{let } 1 + \frac{1}{x^2} + \frac{1}{x^5} = t$$

$$\text{Hence } I = \frac{x^{10}}{2(x^5 + x^3 + 1)^2} + c.$$

41. If the line, $\frac{x-3}{2} = \frac{y+2}{-1} = \frac{z+4}{3}$ lies in the plane, $lx + my - z = 9$, then $l^2 + m^2$ is equal to:

- (1) 18 (2) 5
 (3) 2 (4) 26

Sol. (3)

As line $\frac{x-3}{2} = \frac{y+2}{-1} = \frac{z+4}{3}$ lies in plane $lx + my - z = 9$

So $2l - m - 3 = 0$ (as line is perpendicular to normal of the plane) (1)

Also point (3, -2, -4) lies in plane

So $3l - 2m - 5 = 0$ (2)

From equation (1) and (2), we get $l = 1, m = -1$

So $l^2 + m^2 = 2$

42. If $0 \leq x < 2\pi$, then the number of real values of x , which satisfy the equation $\cos x + \cos 2x + \cos 3x + \cos 4x = 0$ is:

- (1) 5 (2) 7
(3) 9 (4) 3

Sol. (2)

$$2 \cos \frac{5x}{2} \cdot \cos \frac{3x}{2} + 2 \cos \frac{5x}{2} \cdot \cos \frac{x}{2} = 0$$

$$\Rightarrow \cos \frac{5x}{2} \cdot \left(2 \cdot \cos x \cdot \cos \frac{x}{2} \right) = 0$$

$$\Rightarrow \frac{x}{2} = (2n+1)\frac{\pi}{2}, \quad x = (2m+1)\frac{\pi}{2}, \quad \frac{5x}{2} = (2k+1)\frac{\pi}{2}, \quad (\text{where } n, m, k \in \mathbb{Z})$$

$$\Rightarrow x = (2n+1)\pi, \quad x = (2m+1)\frac{\pi}{2}, \quad x = (2k+1)\frac{\pi}{5}$$

$$\Rightarrow x = \pi, \frac{\pi}{2}, \frac{3\pi}{2}, \frac{\pi}{5}, \frac{3\pi}{5}, \frac{7\pi}{5}, \frac{9\pi}{5}.$$

43. The area (in sq. units) of the region $\{(x, y) : y^2 \geq 2x \text{ and } x^2 + y^2 \leq 4x, x \geq 0, y \geq 0\}$ is:

- (1) $\pi - \frac{8}{3}$ (2) $\pi - \frac{4\sqrt{2}}{3}$
(3) $\frac{\pi}{2} - \frac{2\sqrt{2}}{3}$ (4) $\pi - \frac{4}{3}$

Sol. (1)

The point of intersection of the curve $x^2 + y^2 = 4x$ $y^2 = 2x$ are $(0, 0)$ and $(2, 2)$ for $x \geq 0$ and $y \geq 0$

$$\text{So required area} = \frac{1}{4} \pi \times 4 - \int_0^2 \sqrt{2x} dx$$

$$= \pi - \sqrt{2} \cdot \frac{2}{3} [x^{3/2}]_0^2$$

$$= \pi - \frac{8}{3}$$

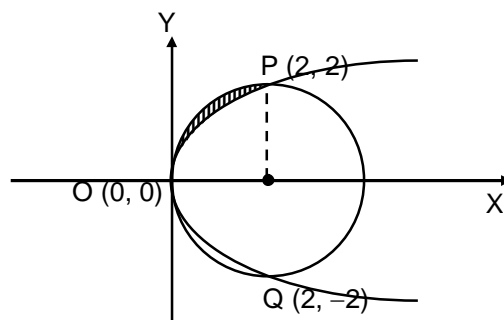

44. Let \vec{a} , \vec{b} and \vec{c} be three unit vectors such that $\vec{a} \times (\vec{b} \times \vec{c}) = \frac{\sqrt{3}}{2}(\vec{b} + \vec{c})$. If \vec{b} is not parallel to \vec{c} , then the angle between \vec{a} and \vec{b} is:

- (1) $\frac{\pi}{2}$ (2) $\frac{2\pi}{3}$
(3) $\frac{5\pi}{6}$ (4) $\frac{3\pi}{4}$

Sol. (3)

$$\vec{a} \times (\vec{b} \times \vec{c}) = \frac{\sqrt{3}}{2}(\vec{b} + \vec{c})$$

$$\Rightarrow (\vec{a} \cdot \vec{c})\vec{b} - (\vec{a} \cdot \vec{b})\vec{c} = \frac{\sqrt{3}}{2}(\vec{b} + \vec{c})$$

$$\Rightarrow \vec{a} \cdot \vec{c} = \frac{\sqrt{3}}{2} \text{ and } \vec{a} \cdot \vec{b} = -\frac{\sqrt{3}}{2}$$

$$\Rightarrow \cos \theta = -\frac{\sqrt{3}}{2} \text{ where } \theta \text{ is angle between } \vec{a} \text{ \& } \vec{b}$$

$$\therefore \theta = \frac{5\pi}{6}$$

45. A wire of length 2 units is cut into two parts which are bent respectively to form a square of side = x units and a circle of radius = r units. If the sum of the areas of the square and the circle so formed is minimum, then:

(1) $(4 - \pi)x = \pi r$

(2) $x = 2r$

(3) $2x = r$

(4) $2x = (\pi + 4)r$

Sol. (2)

$$f(x) = x^2 + \frac{(1-2x)^2}{\pi} \text{ (As } r = \frac{1-2x}{\pi} \text{)}$$

$$f'(x) = 2x - \frac{4(1-2x)}{\pi}$$

$$f''(x) = 2 + \frac{8}{\pi} > 0$$

For minimum value of sum of area $f'(x) = 0$

$$x = \frac{2}{\pi+4} \Rightarrow r = \frac{1}{\pi+4}$$

$$\Rightarrow x = 2r.$$

46. The distance of the point (1, -5, 9) from the plane $x - y + z = 5$ measured along the line $x = y = z$ is:

(1) $10\sqrt{3}$

(2) $\frac{10}{\sqrt{3}}$

(3) $\frac{20}{3}$

(4) $3\sqrt{10}$

Sol. (1)

$$\cos \theta = \frac{1-1+1}{3} = \frac{1}{3}$$

$$\cos \theta = \frac{AP}{AQ}$$

$$AQ = \frac{AP}{\cos \theta} = 10\sqrt{3}$$

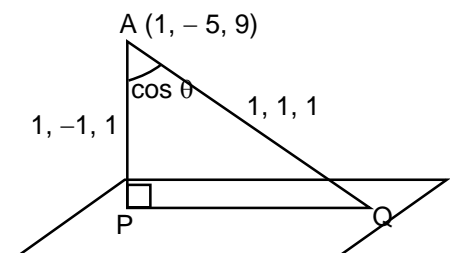

47. If a curve $y = f(x)$ passes through the point (1, -1) and satisfies the differential equation, $y(1 + xy) dx = x dy$, then $f\left(-\frac{1}{2}\right)$ is equal to:

(1) $-\frac{4}{5}$

(2) $\frac{2}{5}$

(3) $\frac{4}{5}$

(4) $-\frac{2}{5}$

Sol. (3)
 $y(1 + xy) dx = xdy$
 $\frac{xdy - ydx}{y^2} = xdx$

$$\int -d\left(\frac{x}{y}\right) = \int xdx$$

$$-\frac{x}{y} = \frac{x^2}{2} + c \text{ as } y(1) = -1 \Rightarrow c = \frac{1}{2}$$

$$\text{Hence } y = \frac{-2x}{x^2 + 1} \Rightarrow f\left(-\frac{1}{2}\right) = \frac{4}{5}.$$

48. If the number of terms in the expansion of $\left(1 - \frac{2}{x} + \frac{4}{x^2}\right)^n$, $x \neq 0$, is 28, then the sum of the coefficients of all the terms in this expansion, is:

- (1) 2187 (2) 243
 (3) 729 (4) 64

Sol. (3)
 Total number of terms $= {}^{n+2}C_2 = 28$
 $(n + 2)(n + 1) = 56$
 $n = 6$

$$\text{Sum of coefficients} = (1 - 2 + 4)^n = 3^6 = 729$$

[*Note: In the solution it is considered that different terms in the expansion having same powers are not merged, as such it should be a bonus question.]

49. Consider $f(x) = \tan^{-1}\left(\sqrt{\frac{1 + \sin x}{1 - \sin x}}\right)$, $x \in \left(0, \frac{\pi}{2}\right)$. A normal to $y = f(x)$ at $x = \frac{\pi}{6}$ also passes through the point:

- (1) $\left(0, \frac{2\pi}{3}\right)$ (2) $\left(\frac{\pi}{6}, 0\right)$
 (3) $\left(\frac{\pi}{4}, 0\right)$ (4) $(0, 0)$

Sol. (1)
 $f(x) = \tan^{-1}\sqrt{\frac{1 + \sin x}{1 - \sin x}}$, where $x \in \left(0, \frac{\pi}{2}\right)$
 $= \tan^{-1}\left(\left|\tan\left(\frac{\pi}{4} + \frac{x}{2}\right)\right|\right)$
 $\Rightarrow f(x) = \frac{\pi}{4} + \frac{x}{2}, \quad f\left(\frac{\pi}{6}\right) = \frac{\pi}{3}$

$$f'(x) = \frac{1}{2}$$

Equation of normal is

$$y - \frac{\pi}{3} = -2\left(x - \frac{\pi}{6}\right)$$

It passes through $\left(0, \frac{2\pi}{3}\right)$.

50. For $x \in \mathbf{R}$, $f(x) = |\log 2 - \sin x|$ and $g(x) = f(f(x))$, then:
- (1) $g'(0) = \cos(\log 2)$
 - (2) $g'(0) = -\cos(\log 2)$
 - (3) g is differentiable at $x = 0$ and $g'(0) = -\sin(\log 2)$
 - (4) g is not differentiable at $x = 0$

Sol. (1)
 At $x = 0$, f is differential and $f'(0) = -\cos 0 = -1$
 $g'(0) = f'(f(0)) \cdot f'(0)$
 $= -\cos(\log 2) \times -1$ (at $x = 0$, $f(0) = \log 2$)
 $= \cos(\log 2)$

51. Let two fair six-faced dice A and B be thrown simultaneously. If E_1 is the event that die A shows up four, E_2 is the event that die B shows up two and E_3 is the event that the sum of numbers on both dice is odd, then which of the following statements is **NOT true**?
- (1) E_2 and E_3 are independent.
 - (2) E_1 and E_3 are independent.
 - (3) E_1, E_2 and E_3 are independent.
 - (4) E_1 and E_2 are independent.

Sol. (3)
 $P(E_1) = \frac{1}{6}$, $P(E_2) = \frac{1}{6}$, $P(E_3) = \frac{1}{2}$
 Also $P(E_1 \cap E_2) = \frac{1}{36}$, $P(E_2 \cap E_3) = \frac{1}{12}$, $P(E_1 \cap E_3) = \frac{1}{12}$
 And $P(E_1 \cap E_2 \cap E_3) = 0 \neq P(E_1) \cdot P(E_2) \cdot P(E_3)$
 Hence, E_1, E_2, E_3 are not independent.

52. If $A = \begin{bmatrix} 5a & -b \\ 3 & 2 \end{bmatrix}$ and $A \text{ adj } A = A A^T$, then $5a + b$ is equal to:
- (1) 5
 - (2) 4
 - (3) 13
 - (4) -1

Sol. (1)
 $A \text{ adj } A = |A| I_n = \begin{bmatrix} 5a & -b \\ 3 & 2 \end{bmatrix} \begin{bmatrix} 5a & 3 \\ -b & 2 \end{bmatrix}$
 $\Rightarrow (10a + 3b) \begin{bmatrix} 1 & 0 \\ 0 & 1 \end{bmatrix} = \begin{bmatrix} 25a^2 + b^2 & 15a - 2b \\ 15a - 2b & 13 \end{bmatrix}$
 $\Rightarrow 15a - 2b = 0$ and $10a + 3b = 13$
 $\Rightarrow 5a + b = 5 \times \frac{2}{5} + 3 = 5$.

53. The Boolean Expression $(p \wedge \sim q) \vee q \vee (\sim p \wedge q)$ is equivalent to:
- (1) $p \wedge q$
 - (2) $p \vee q$
 - (3) $p \vee \sim q$
 - (4) $\sim p \wedge q$

Sol. (2)
 $(p \wedge \sim q) \vee q \vee (\sim p \wedge q)$
 $\equiv \{(p \vee q) \wedge (\sim q \vee q)\} \vee (\sim p \wedge q)$
 $\equiv \{(p \vee q) \wedge T\} \vee (\sim p \wedge q)$
 $\equiv (p \vee q) \vee (\sim p \wedge q)$
 $\equiv \{(p \vee q) \vee \sim p\} \wedge (p \vee q \vee q)$
 $\equiv T \wedge (p \vee q)$
 $\equiv p \vee q$

54. The sum of all real values of x satisfying the equation

$$(x^2 - 5x + 5)^{x^2 + 4x - 60} = 1 \text{ is}$$

- (1) -4 (2) 6
 (3) 5 (4) 3

Sol. (4)

Either $x^2 - 5x + 5 = 1$ or $x^2 + 4x - 60 = 0$

$x = 1, 4$ or $x = -10, 6$

Also $x^2 - 5x + 5 = -1$ and $x^2 + 4x - 60 \in$ even number

$x = 2, 3$

For $x = 3$ $x^2 + 4x - 60$ is odd

Total solutions are $x = 1, 4, -10, 6, 2$

\Rightarrow Sum = 3

55. The centres of those circles which touch the circle, $x^2 + y^2 - 8x - 8y - 4 = 0$, externally and also touch the x -axis, lie on:

- (1) an ellipse which is not a circle. (2) a hyperbola.
 (3) a parabola. (4) a circle.

Sol. (3)

Let (h, k) be the centre of the circle which touch x -axis and $x^2 + y^2 - 8x - 8y - 4 = 0$ externally.

\Rightarrow Radius of that circle is $|k|$

$$\Rightarrow (h - 4)^2 + (k - 4)^2 = (|k| + 6)^2$$

$$\Rightarrow x^2 - 8x - 20y - 4 = 0 \text{ if } y \geq 0$$

$$\text{and } x^2 - 8x + 4y - 4 = 0 \text{ if } y < 0$$

\Rightarrow The curve is parabola.

56. If all the words (with or without meaning) having five letters, formed using the letters of the word SMALL and arranged as in a dictionary; then the position of the word SMALL is:

- (1) 59^{th} (2) 52^{nd}
 (3) 58^{th} (4) 46^{th}

Sol. (3)

$$\text{Words starting with A, L, M} = \frac{4!}{2!} + 4! + \frac{4!}{2!} = 48$$

$$\text{Words starting with SA, SL} = \frac{3!}{2!} + 3! = 9$$

\Rightarrow Rank of the word SMALL = 58.

57. $\lim_{n \rightarrow \infty} \left(\frac{(n+1)(n+2)\dots 3n}{n^{2n}} \right)^{1/n}$ is equal to:

- (1) $\frac{27}{e^2}$ (2) $\frac{9}{e^2}$
 (3) $3 \log 3 - 2$ (4) $\frac{18}{e^4}$

Sol. (1)

$$\ln y = \lim_{n \rightarrow \infty} \frac{1}{n} \cdot \log \left(1 + \frac{1}{n} \right) \left(1 + \frac{2}{n} \right) \dots \left(1 + \frac{2n}{n} \right)$$

$$= \frac{1}{n} \cdot \sum_{r=1}^{2n} \ln \left(1 + \frac{r}{n} \right)$$

$$\ln y = \int_0^2 \ln(1+x) dx, \quad \text{let } t = 1+x$$

$$= \int_1^3 \ln t \, dt$$

$$= \ln \frac{27}{e^2}$$

58. If the sum of the first ten terms of the series $\left(1\frac{3}{5}\right)^2 + \left(2\frac{2}{5}\right)^2 + \left(3\frac{1}{5}\right)^2 + 4^2 + \left(4\frac{4}{5}\right)^2 + \dots$, is $\frac{16}{5}m$, then m is equal to:
- (1) 101 (2) 100
 (3) 99 (4) 102

Sol. (1)

$$\text{Let } S = \left(\frac{8}{5}\right)^2 + \left(\frac{12}{5}\right)^2 + \left(\frac{16}{5}\right)^2 + \left(\frac{20}{5}\right)^2 + \dots + \left(\frac{44}{5}\right)^2$$

$$\Rightarrow S = \frac{16}{25} [2^2 + 3^2 + 4^2 + 5^2 + \dots + 11^2]$$

$$\Rightarrow S = \frac{16}{25} [1^2 + 2^2 + \dots + 11^2 - 1] = \frac{16}{5} \times 101$$

$$\Rightarrow m = 101$$

59. If one of the diameters of the circle, given by the equation, $x^2 + y^2 - 4x + 6y - 12 = 0$, is a chord of a circle S , whose centre is at $(-3, 2)$, then the radius of S is:
- (1) $5\sqrt{3}$ (2) 5
 (3) 10 (4) $5\sqrt{2}$

Sol. (1)

Let 'r' be the radius of circle S
 $\Rightarrow r = 5\sqrt{3}$

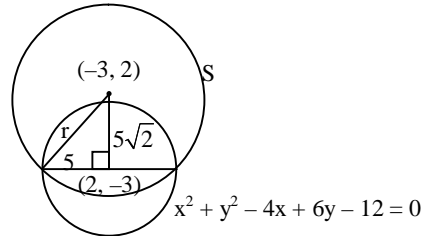

60. A man is walking towards a vertical pillar in a straight path, at a uniform speed. At a certain point A on the path, he observes that the angle of elevation of the top of the pillar is 30° . After walking for 10 minutes from A in the same direction, at a point B , he observes that the angle of elevation of the top of the pillar is 60° . Then the time taken (in minutes) by him, from B to reach the pillar, is:
- (1) 10 (2) 20
 (3) 5 (4) 6

Sol. (3)

$$\tan 60^\circ = \frac{h}{x} \Rightarrow h = \sqrt{3}x$$

$$\tan 30^\circ = \frac{h}{x+y} \Rightarrow \sqrt{3}h = x+y$$

$$3x = x+y$$

$$\Rightarrow 2x = y$$

Time taken from A to B is 10 min
 So time taken from B to pillar is 5 min

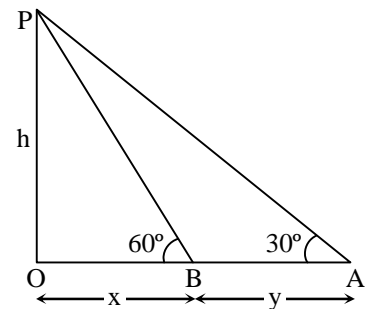

PART C – PHYSICS

61. A uniform string of length 20 m is suspended from a rigid support. A short wave pulse is introduced at its lowest end. It starts moving up the string. The time taken to reach the support is : (take $g = 10 \text{ ms}^{-2}$)

- (1) 2s (2) $2\sqrt{2}$ s
(3) $\sqrt{2}$ s (4) $2\pi\sqrt{2}$ s

Sol. (2)

$$T(x) = \frac{Mgx}{L}$$

$$\Rightarrow v(x) = \sqrt{\frac{T}{\mu}} = \sqrt{gx}$$

$$\Rightarrow \frac{dx}{dt} = \sqrt{gx} \Rightarrow \text{time taken} = 2\sqrt{2} \text{ s.}$$

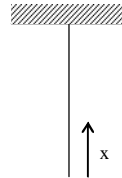

62. A person trying to lose weight by burning fat lifts a mass of 10 kg upto a height of 1 m 1000 times. Assume that the potential energy lost each time he lowers the mass is dissipated. How much fat will he use up considering the work done only when the weight is lifted up? Fat supplies $3.8 \times 10^7 \text{ J}$ of energy per kg which is converted to mechanical energy with a 20 % efficiency rate. Take $g = 9.8 \text{ ms}^{-2}$:

- (1) $6.45 \times 10^{-3} \text{ kg}$ (2) $9.89 \times 10^{-3} \text{ kg}$
(3) $12.89 \times 10^{-3} \text{ kg}$ (4) $2.45 \times 10^{-3} \text{ kg}$

Sol. (3)

Let fat used be 'x' kg

$$\Rightarrow \text{Mechanical energy available} = x \times 3.8 \times 10^7 \times \frac{20}{100}$$

$$\text{Work done in lifting up} = 10 \times 9.8 \times 1000$$

$$\Rightarrow x \times 3.8 \times 10^7 \times \frac{20}{100} = 9.8 \times 10^4$$

$$\Rightarrow x \approx 12.89 \times 10^{-3} \text{ kg.}$$

63. A point particle of mass m, moves along the uniformly rough track PQR as shown in the figure. The coefficient of friction, between the particle and the rough track equals μ . The particle is released, from rest, from the point P and it comes to rest at a point R. The energies, lost by the ball, over the parts, PQ and QR, of the track, are equal to each other, and no energy is lost when particle changes direction from PQ to QR.

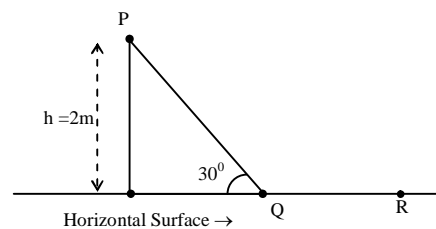

The values of the coefficient of friction μ and the distance $x(=QR)$, are, respectively close to :

- (1) 0.2 and 3.5 m (2) 0.29 and 3.5 m
(3) 0.29 and 6.5 m (4) 0.2 and 6.5 m

Sol. (2)

Since work done by friction on parts PQ and QR are equal

$$-\mu mg \times \frac{\sqrt{3}}{2} \times 4 = -\mu mgx \quad (\text{QR} = x)$$

$$\Rightarrow x = 2\sqrt{3} \text{ m} \approx 3.5 \text{ m}$$

Applying work energy theorem from P to R

$$mg \sin 30^\circ \times 4 - \mu mg \frac{\sqrt{3}}{2} \times 4 - \mu mgx = 0$$

$$\Rightarrow \mu = \frac{1}{2\sqrt{3}} \approx 0.29.$$

64. Two identical wires A and B, each of length ' ℓ ', carry the same current I. Wire A is bent into a circle of radius R and wire B is bent to form a square of side 'a'. If B_A and B_B are the values of magnetic field at the centres of the circle and square respectively, then the ratio $\frac{B_A}{B_B}$ is :

(1) $\frac{\pi^2}{16\sqrt{2}}$

(2) $\frac{\pi^2}{16}$

(3) $\frac{\pi^2}{8\sqrt{2}}$

(4) $\frac{\pi^2}{8}$

Sol. (3)

$$B_A = \frac{\mu_0}{4\pi} \frac{2\pi i}{(\ell/2\pi)}$$

$$B_B = \left[\frac{\mu_0}{4\pi} \frac{i}{\ell/8} (\sin 45^\circ + \sin 45^\circ) \right] \times 4$$

$$\frac{B_A}{B_B} = \frac{\pi^2}{8\sqrt{2}}$$

65. A galvanometer having a coil resistance of 100Ω gives a full scale deflection, when a current of 1 mA is passed through it. The value of the resistance, which can convert this galvanometer into ammeter giving a full scale deflection for a current of 10 A is :

(1) 2Ω

(2) 0.1Ω

(3) 3Ω

(4) 0.01Ω

Sol. (4)

For full scale deflection

$$100 \times i_g = (i - i_g)S$$

where 'S' is the required resistance

$$S = \frac{100 \times 1 \times 10^{-3}}{(10 - 10^{-3})}$$

$$S \approx 0.01 \Omega$$

66. An observer looks at a distant tree of height 10 m with a telescope of magnifying power of 20. To the observer the tree appears :

(1) 10 times nearer.

(2) 20 times taller.

(3) 20 times nearer.

(4) 10 times taller.

Sol. (3)

67. The temperature dependence of resistances of **Cu** and undoped **Si** in the temperature range 300 – 400 K, is best described by :

(1) Linear increase for Cu, exponential increase for Si.

(2) Linear increase for Cu, exponential decrease for Si.

(3) Linear decrease for Cu, linear decrease for Si.

(4) Linear increase for Cu, linear increase for Si.

Sol. (2)

The electric resistance of a typical intrinsic (undoped) semiconductor decreases exponentially with temperature

$$\rho = \rho_0 e^{-aT}$$

where a is a constant.

68. Choose the correct statement :

- (1) In amplitude modulation the frequency of the high frequency carrier wave is made to vary in proportion to the amplitude of the audio signal.
- (2) In frequency modulation the amplitude of the high frequency carrier wave is made to vary in proportion to the amplitude of the audio signal.
- (3) In frequency modulation the amplitude of the high frequency carrier wave is made to vary in proportion to the frequency of the audio signal.
- (4) In amplitude modulation the amplitude of the high frequency carrier wave is made to vary in proportion to the amplitude of the audio signal.

Sol. (4)

In amplitude modulation amplitude of carrier wave varies in proportion to applied signal.

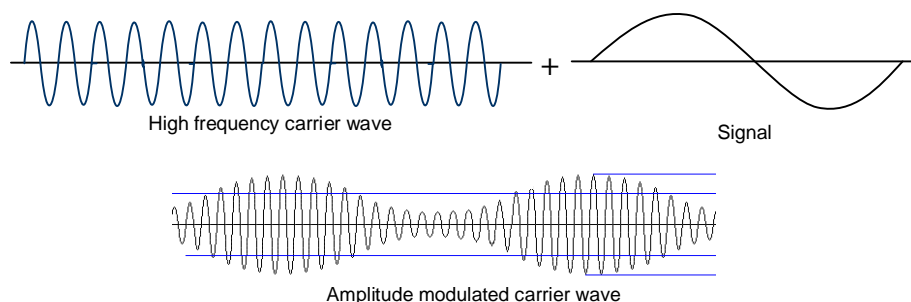

69. Half-lives of two radioactive elements A and B are 20 minutes and 40 minutes, respectively. Initially, the samples have equal number of nuclei. After 80 minutes, the ratio of decayed numbers of A and B nuclei will be :

- (1) 4 : 1
- (2) 1 : 4
- (3) 5 : 4
- (4) 1 : 16

Sol. (3)

$$\text{for A: } N_0 - \frac{N_0}{2^4} = \frac{15N_0}{16}$$

$$\text{for B: } N_0 - \frac{N_0}{2^2} = \frac{3N_0}{4}$$

The required ratio is $\frac{5}{4}$

70. 'n' moles of an ideal gas undergoes a process A \rightarrow B as shown in the figure. The maximum temperature of the gas during the process will be :

- (1) $\frac{3P_0 V_0}{2nR}$
- (2) $\frac{9P_0 V_0}{2nR}$
- (3) $\frac{9P_0 V_0}{nR}$
- (4) $\frac{9P_0 V_0}{4nR}$

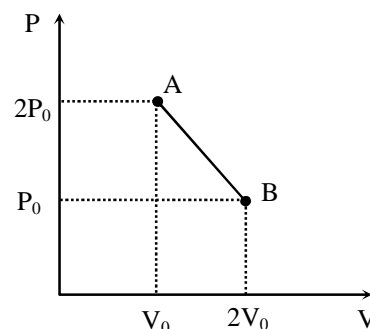

Sol. (4)

Equation of line is

$$PV_0 + P_0V = 3P_0V_0 \quad \dots(i)$$

$$\text{Also } PV = nRT \quad \dots(ii)$$

$$\text{for } T_{\max}, \frac{dT}{dV} = 0$$

$$\Rightarrow V = \frac{3V_0}{2}, P = \frac{3P_0}{2}$$

$$\Rightarrow T_{\max} = \frac{9P_0V_0}{4nR}$$

71. An arc lamp requires a direct current of 10 A and 80 V to function. If it is connected to a 220 V (rms), 50 Hz AC supply, the series inductor needed for it to work is close to :

- (1) 0.08 H (2) 0.044 H
(3) 0.065 H (4) 80 H

Sol. (3)

For the lamp with direct current,

$$V = IR$$

$$\Rightarrow R = 8\Omega \text{ and } P = 80 \times 10 = 800 \text{ W}$$

For ac supply

$$P = I_{\text{rms}}^2 R = \frac{\varepsilon_{\text{rms}}^2}{Z^2} R$$

$$\Rightarrow Z^2 = \frac{(220)^2 \times 8}{800}$$

$$\Rightarrow Z = 22\Omega$$

$$\Rightarrow R^2 + \omega^2 L^2 = (22)^2$$

$$\Rightarrow \omega L = \sqrt{420}$$

$$\Rightarrow L = 0.065 \text{ H}$$

72. A pipe open at both ends has a fundamental frequency f in air. The pipe is dipped vertically in water so that half of it is in water. The fundamental frequency of the air column is now :

- (1) $\frac{3f}{4}$ (2) $2f$
(3) f (4) $\frac{f}{2}$

Sol. (3)

For open pipe in air, fundamental frequency:

$$f = \frac{V}{2\ell}$$

For the pipe closed at one end (dipped in water), fundamental frequency:

$$f' = \frac{V}{4\ell'} = \frac{V}{4 \times \frac{\ell}{2}} = \frac{V}{2\ell}$$

$$\therefore f' = f$$

73. The box of pin hole camera, of length L , has a hole of radius a . It is assumed that when the hole is illuminated by a parallel beam of light of wavelength λ the spread of the spot (obtained on the opposite wall of the camera) is the sum of its geometrical spread and the spread due to diffraction. The spot would then have its minimum size (say b_{\min}) when :

(1) $a = \sqrt{\lambda L}$ and $b_{\min} = \left(\frac{2\lambda^2}{L}\right)$ (2) $a = \sqrt{\lambda L}$ and $b_{\min} = \sqrt{4\lambda L}$

(3) $a = \frac{\lambda^2}{L}$ and $b_{\min} = \sqrt{4\lambda L}$ (4) $a = \frac{\lambda^2}{L}$ and $b_{\min} = \left(\frac{2\lambda^2}{L}\right)$

Sol. (2)

We know that

Geometrical spread = a

and diffraction spread = $\frac{\lambda L}{a}$

so spot size(b) = $a + \frac{\lambda L}{a}$

for minimum spot size $a = \frac{\lambda L}{a}$

$$\Rightarrow a = \sqrt{\lambda L}$$

$$\text{and } b_{\min} = \sqrt{\lambda L} + \sqrt{\lambda L} = \sqrt{4\lambda L}$$

74. A combination of capacitors is set up as shown in the figure. The magnitude of the electric field, due to a point charge Q (having a charge equal to the sum of the charges on the $4 \mu\text{F}$ and $9 \mu\text{F}$ capacitors), at a point distant 30 m from it, would equal :

- (1) 360 N/C
 (2) 420 N/C
 (3) 480 N/C
 (4) 240 N/C

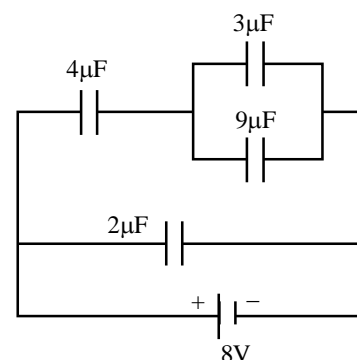

Sol. (2)

Charge on $9 \mu\text{F}$ capacitor = $18 \mu\text{C}$

Charge on $4 \mu\text{F}$ capacitor = $24 \mu\text{C}$

$$\therefore Q = 24 + 18 = 42 \mu\text{C}$$

$$\therefore \frac{KQ}{r^2} = \frac{9 \times 10^9 \times 42 \times 10^{-6}}{(30)^2} = 420 \text{ N/C}$$

75. Arrange the following electromagnetic radiations per quantum in the order of increasing energy :

A : Blue light B : Yellow light

C : X-ray D : Radiowave

(1) A, B, D, C

(2) C, A, B, D

(3) B, A, D, C

(4) D, B, A, C

Sol. (4)

Radiation energy per quantum is

$$E = h\nu$$

As per EM spectrum, the increasing order of frequency and hence energy is

Radio wave < Yellow light < Blue light < X Ray

76. Hysteresis loops for two magnetic materials A and B are given below :

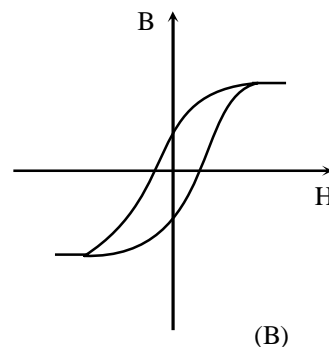
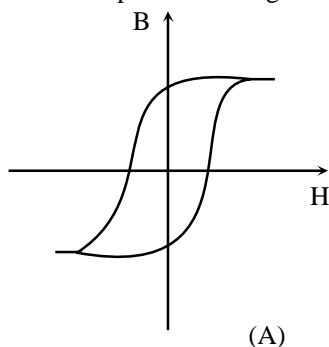

These materials are used to make magnets for electric generators, transformer core and electromagnet core. Then it is proper to use :

- (1) A for electromagnets and B for electric generators
- (2) A for transformers and B for electric generators
- (3) B for electromagnets and transformers
- (4) A for electric generators and transformers

Sol. (3)

For electromagnet and transformer, the coercivity should be low to reduce energy loss

77. A pendulum clock loses 12 s a day if the temperature is 40°C and gains 4 s a day if the temperature is 20°C . The temperature at which the clock will show correct time, and the co-efficient of linear expansion (α) of the metal of the pendulum shaft are respectively :

- (1) 60°C ; $\alpha = 1.85 \times 10^{-4}/^\circ\text{C}$
- (2) 30°C ; $\alpha = 1.85 \times 10^{-3}/^\circ\text{C}$
- (3) 55°C ; $\alpha = 1.85 \times 10^{-2}/^\circ\text{C}$
- (4) 25°C ; $\alpha = 1.85 \times 10^{-5}/^\circ\text{C}$

Sol. (4)

First Method

$$\text{Time period } T = 2\pi\sqrt{\frac{\ell}{g}} = 2\pi\sqrt{\frac{\ell_0}{g}(1 + \alpha\Delta\theta)}$$

$$T = T_0 \left[1 + \frac{1}{2}\alpha\Delta\theta \right]$$

$$N = \frac{2 \times 86400}{T} = \left(\frac{2 \times 86400}{T_0} \right) \left(1 + \frac{1}{2}\alpha\Delta\theta \right) = N \left(1 + \frac{\alpha\Delta\theta}{2} \right)$$

$$\Delta N = N - N_0 = \frac{1}{2}\alpha\Delta\theta N_0 \Rightarrow \Delta N \propto \Delta\theta$$

$$\Rightarrow \theta_0 = 25^\circ\text{C}$$

Putting θ_0 , we get $\alpha = 1.85 \times 10^{-5}/^\circ\text{C}$

Second Method

According to given conditions

$$86412 = 2\pi\sqrt{\frac{\ell_{40}}{g}} \quad \dots(i)$$

$$86396 = 2\pi\sqrt{\frac{\ell_{20}}{g}} \quad \dots(ii)$$

$$86400 = 2\pi\sqrt{\frac{\ell}{g}} \quad \dots(iii)$$

From equation (i) and (iii)

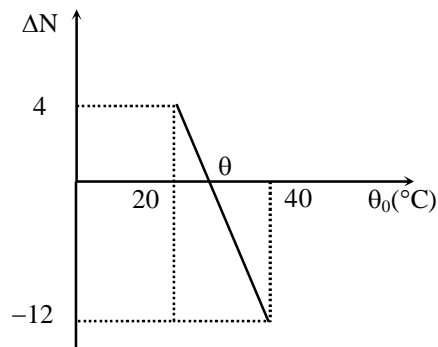

$$12 = \frac{2\pi}{\sqrt{g}} [\sqrt{\ell_{40}} - \sqrt{\ell}] \quad \dots(\text{iv})$$

$$\text{and } 4 = \frac{2\pi}{\sqrt{g}} [\sqrt{\ell} - \sqrt{\ell_{20}}] \quad \dots(\text{v})$$

on dividing (iv) and (v)

$$3 = \frac{\sqrt{1 + \alpha(40 - \theta)} - 1}{1 - \sqrt{1 + \alpha(20 - \theta)}}$$

$$\Rightarrow 3 = \frac{40 - \theta}{\theta - 20} \quad (\text{by Binomial theorem})$$

$$\Rightarrow \theta = 25^\circ$$

on using θ in (i) and (iii)

$$\frac{86412}{86400} = \sqrt{1 + \alpha 15} \Rightarrow \alpha = 1.85 \times 10^{-5} / ^\circ\text{C}$$

78. The region between two concentric spheres of radii 'a' and 'b', respectively (see figure), has volume charge density $\rho = \frac{A}{r}$, where A is a constant and r is the distance from the centre. At the centre of the spheres is a point charge Q. The value of A such that the electric field in the region between the spheres will be constant, is :

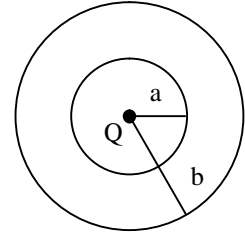

- (1) $\frac{Q}{2\pi(b^2 - a^2)}$ (2) $\frac{2Q}{\pi(a^2 - b^2)}$
 (3) $\frac{2Q}{\pi a^2}$ (4) $\frac{Q}{2\pi a^2}$

Sol. (4)

According Gauss's law, we can write,

$$E \times 4\pi r^2 = \frac{1}{\epsilon_0} \left[Q + \int_a^r \left(\frac{A}{r} \right) (4\pi r^2 dr) \right] = \frac{1}{\epsilon_0} [Q + 2\pi A(r^2 - a^2)]$$

For E to be independent of r,

$$Q - 2\pi A a^2 = 0 \Rightarrow a = \frac{Q}{2\pi a^2}$$

79. In an experiment for determination of refractive index of glass of a prism by $i - \delta$, plot, it was found that a ray incident at angle 35° , suffers a deviation of 40° and that it emerges at angle 79° . In that case which of the following is closest to the maximum possible value of the refractive index ?

- (1) 1.6 (2) 1.7
 (3) 1.8 (4) 1.5

Sol. (4)

$$\delta = i + e - A \Rightarrow A = 74^\circ$$

$$\mu = \frac{\sin\left(\frac{A + \delta_{\min}}{2}\right)}{\sin\left(\frac{A}{2}\right)} = \frac{5}{3} \sin\left(37^\circ + \frac{\delta_{\min}}{2}\right)$$

$$\mu_{\max} \text{ can be } \frac{5}{3}, \text{ so } \mu \text{ will be less than } \frac{5}{3}$$

Since δ_{\min} will be less than 40° , so

$$\mu < \frac{5}{3} \sin 57^\circ < \frac{5}{3} \sin 60^\circ \Rightarrow \mu < 1.446$$

So the nearest possible value of μ should be 1.5

80. A student measures the time period of 100 oscillations of a simple pendulum four times. The data set is 90s, 91s, 95s and 92s. If the minimum division in the measuring clock is 1s, then the reported mean time should be :

- (1) $92 \pm 5.0s$ (2) $92 \pm 1.8s$
 (3) $92 \pm 3s$ (4) $92 \pm 2s$

Sol. (4)

$$t = \frac{t_1 + t_2 + t_3 + t_4}{4} = \frac{90 + 91 + 95 + 92}{4} = 92$$

$$\text{Now mean deviation is equal to } \left(\frac{2 + 1 + 3 + 0}{4} \right) = 1.5$$

Since least count of clock is one second, so $\Delta t = 2 \text{ sec}$

81. Identify the semiconductor devices whose characteristics are given below, in the order (a), (b), (c), (d) :

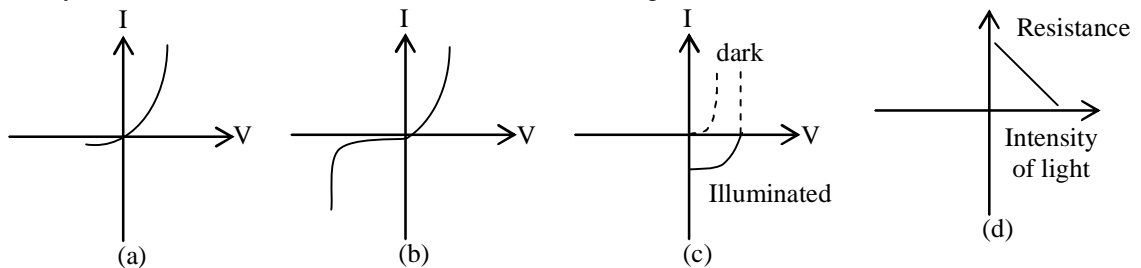

- (1) Zener diode, Simple diode, Light dependent resistance, Solar cell
 (2) Solar cell, Light dependent resistance, Zener diode, Simple diode
 (3) Zener diode, Solar cell, Simple diode, Light dependent resistance
 (4) Simple diode, Zener diode, Solar cell, Light dependent resistance

Sol. (4)

82. Radiation of wavelength λ , is incident on a photocell. The fastest emitted electron has speed v . If the wavelength is changed to $\frac{3\lambda}{4}$, the speed of the fastest emitted electron will be :

- (1) $< v \left(\frac{4}{3} \right)^{\frac{1}{2}}$ (2) $= v \left(\frac{4}{3} \right)^{\frac{1}{2}}$
 (3) $= v \left(\frac{3}{4} \right)^{\frac{1}{2}}$ (4) $> v \left(\frac{4}{3} \right)^{\frac{1}{2}}$

Sol. (4)

$$\frac{hc}{\lambda} - \phi = \frac{1}{2} mv^2 \quad \dots(i)$$

$$\frac{4hc}{3\lambda} - \phi = \frac{1}{2} mv_1^2 \quad \dots(ii)$$

$$\text{So, } \frac{hc}{3\lambda} = \frac{1}{2} m(v_1^2 - v^2)$$

$$\frac{1}{3} \left(\frac{1}{2} m v^2 + \phi \right) = \frac{1}{2} m (v_1^2 - v^2)$$

$$\therefore v_1 > v \left(\frac{4}{3} \right)^{\frac{1}{2}}$$

83. A particle performs simple harmonic motion with amplitude A . Its speed is trebled at the instant that it is at a distance $\frac{2A}{3}$ from equilibrium position. The new amplitude of the motion is :

- (1) $3A$ (2) $A\sqrt{3}$
 (3) $\frac{7A}{3}$ (4) $\frac{A}{3}\sqrt{41}$

Sol. (3)

$$3\omega \sqrt{A^2 - \left(\frac{2A}{3}\right)^2} = \omega \sqrt{A_1^2 - \left(\frac{2A}{3}\right)^2}$$

$$\therefore A_1 = \frac{7A}{3}$$

84. A particle of mass m is moving along the side of a square of side 'a', with a uniform speed v in the x-y plane as shown in the figure :
 Which of the following statements is **false** for the angular momentum \vec{L} about the origin ?

- (1) $\vec{L} = mv \left[\frac{R}{\sqrt{2}} - a \right] \hat{k}$ when the particle is moving from C to D.
 (2) $\vec{L} = mv \left[\frac{R}{\sqrt{2}} + a \right] \hat{k}$ when the particle is moving from B to C.
 (3) $\vec{L} = \frac{mv}{\sqrt{2}} R \hat{k}$ when the particle is moving from D to A.
 (4) $\vec{L} = -\frac{mv}{\sqrt{2}} R \hat{k}$ when the particle is moving from A to B.

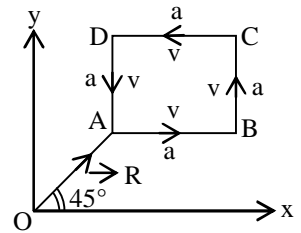

Sol. (1, 3)

$$\vec{L}_O = mv \frac{R}{\sqrt{2}} (-\hat{k}) \quad [\text{D to A}]$$

$$\vec{L}_O = mv \left[\frac{R}{\sqrt{2}} + a \right] \hat{k} \quad [\text{C to D}]$$

85. An ideal gas undergoes a quasi static, reversible process in which its molar heat capacity C remains constant. If during this process the relation of pressure P and volume V is given by $PV^n = \text{constant}$, then n is given by (Here C_p and C_v are molar specific heat at constant pressure and constant volume, respectively):

- (1) $n = \frac{C - C_p}{C - C_v}$ (2) $n = \frac{C_p - C}{C - C_v}$
 (3) $n = \frac{C - C_v}{C - C_p}$ (4) $n = \frac{C_p}{C_v}$

Sol. (1)

$$C = C_v - \frac{R}{n-1}$$

$$\frac{R}{n-1} = C_v - C$$

$$n = \frac{C - C_p}{C - C_v}$$

86. A screw gauge with a pitch of 0.5 mm and a circular scale with 50 divisions is used to measure the thickness of a thin sheet of Aluminium. Before starting the measurement, it is found that when the two jaws of the screw gauge are brought in contact, the 45th division coincides with the main scale line and that the zero of the main scale is barely visible. What is the thickness of the sheet if the main scale reading is 0.5 mm and the 25th division coincides with the main scale line ?

- (1) 0.80 mm (2) 0.70 mm
 (3) 0.50 mm (4) 0.75 mm

Sol. (1)

$$\text{Reading} = 0.5 + 25 \left(\frac{0.5}{50} \right) + 5 \left(\frac{0.5}{50} \right) = 0.8 \text{ mm}$$

87. A roller is made by joining together two cones at their vertices O. It is kept on two rails AB and CD which are placed asymmetrically (see figure), with its axis perpendicular to CD and its centre O at the centre of line joining AB and CD (see figure). It is given a light push so that it starts rolling with its centre O moving parallel to CD in the direction shown. As it moves, the roller will tend to :

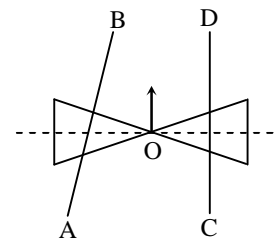

- (1) turn right (2) go straight
 (3) turn left and right alternately (4) turn left

Sol. (4)

From normal reactions of roller, we can conclude it moves towards left.

88. If a, b, c, d are inputs to a gate and x is its output, then, as per the following time graph, the gate is :

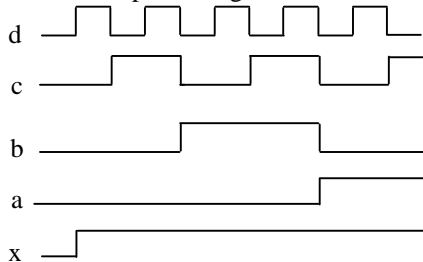

- (1) AND (2) OR
 (3) NAND (4) NOT

Sol. (2)

From truth Table, it is OR gate.

89. For a common emitter configuration, if α and β have their usual meanings, the incorrect relationship between α and β is :

- (1) $\alpha = \frac{\beta}{1-\beta}$ (2) $\alpha = \frac{\beta}{1+\beta}$
 (3) $\alpha = \frac{\beta^2}{1+\beta^2}$ (4) $\frac{1}{\alpha} = \frac{1}{\beta} + 1$

Sol. (1, 3)

$\beta = \frac{\alpha}{1-\alpha}$, is not satisfied by option (1, 3)

90. A satellite is revolving in a circular orbit at a height 'h' from the earth's surface (radius of earth R; $h \ll R$). The minimum increase in its orbital velocity required, so that the satellite could escape from the earth's gravitational field, is close to : (Neglect the effect of atmosphere.)

- (1) \sqrt{gR} (2) $\sqrt{gR/2}$
(3) $\sqrt{gR}(\sqrt{2}-1)$ (4) $\sqrt{2gR}$

Sol. (3)

At height h escape velocity

$$V_e = \sqrt{\frac{2GM}{R+h}}$$

$$\text{Orbital velocity } V_0 = \sqrt{\frac{GM}{R+h}}$$

\therefore Increase in orbital velocity required to escape gravitational field

$$\Rightarrow V_e - V_0$$

$$\Rightarrow \sqrt{gR}(\sqrt{2}-1)$$